

# Technical Specifications Guide For Fasteners



Office No.02, 1st Floor, Shreeji Plaza, CHS Tata Road  
No 02 , Opera House, Charni Road Mumbai - 400004



[info@adcoforge.com](mailto:info@adcoforge.com)

GST NO : 27AAXCA2226N1Z4



+91-22-6659 5582 / 6659 5581 /  
4602 5379 (15 Lines)



[www.adcoforge.com](http://www.adcoforge.com)

## Important Disclaimer

*All of the information provided in this publication is intended for reference purposes only. The publisher is merely furnishing information and does not warrant or guarantee the completeness or the accuracy of the information provided herein. There is no effort on the publisher's part toward price fixing or regulating prices. Publisher assumes no responsibility for loss, claims, or damages resulting from use of the information in this catalog.*



## TECHNICAL INFORMATION

A-1

<b>A</b>	
<b>Anchors–Application &amp; Drilling Information</b> .....	A-45, A-46
<b>B</b>	
<b>Bolts</b>	
ASTM and SAE Specifications, Proof Loads & Tensile Strengths.....	A-14
Carriage.....	A-19
Elevator.....	A-18
Heavy Hex.....	A-16
Plow.....	A-18
Square Head.....	A-17
Step.....	A-18
Structural–Grip Ranges.....	A-15
<b>C</b>	
<b>Cotter Pins</b> .....	A-30
<b>D</b>	
<b>Dowel Pins</b> .....	A-32
<b>Drive Screws–Type U</b> .....	A-30
<b>H</b>	
<b>Heat-Treated Alloy Studs, Bolts &amp; Threaded Bars</b> .....	A-4
<b>Hex Head Cap Screws</b> .....	A-16
<b>High-Strength Dimensional Data–Bolts, Nuts &amp; Washers</b> .....	A-5
<b>Hole Guide</b> .....	A-48
<b>L</b>	
<b>Lag Screws</b> .....	A-17
<b>Length Tolerances for Screws</b> .....	A-20
<b>M</b>	
<b>Machine Screws</b>	
Binding Head.....	A-21
Fillister Head.....	A-22
Flat Head.....	A-23
Flat Head Undercut.....	A-24
Oval Head.....	A-25
Pan Head.....	A-26
Round Head.....	A-27
Truss Head.....	A-28
<b>Mechanical Requirements–Bolts, Screws, SEMS, Studs, &amp; U-Bolts</b> .....	A-3
<b>Metric</b>	
Bolts, Hex Head.....	A-39
Cap Screws, Hex Head.....	A-39
Conversion Guide.....	A-35
Machine Screws, Flat Head.....	A-40
Machine Screws, Oval Head.....	A-41
Machine Screws, Pan Head.....	A-42
Nuts, Hex.....	A-36

### Metric (Continued)

Nuts, Jam.....	A-36
Socket Screws, Button Head.....	A-44
Socket Screws, Flat Head.....	A-43
Socket Screws, Socket Head Cap.....	A-43
Socket Set Screws.....	A-44
Tap Drill Guide.....	A-50
Thread and Din Information.....	A-34
Washers, External Tooth Lock.....	A-38
Washers, Flat.....	A-37
Washers, Internal Tooth Lock.....	A-38
Washers, Split Lock.....	A-37
<b>N</b>	
<b>Nuts</b>	
Hex Nut Markings and Properties.....	A-7
Machine Screw–Hex & Square.....	A-8
Square, Regular.....	A-8
Finished Hex.....	A-9
Heavy Hex.....	A-9
Jam.....	A-10
“K” Lock.....	A-11
<b>S</b>	
<b>Self-Drilling Screws</b> .....	A-26
<b>Shoulder Screws</b> .....	A-33
<b>Socket Screws</b>	
Button Head.....	A-31
Flat Head.....	A-32
Shoulder.....	A-33
Socket Head Cap.....	A-31
Socket Set.....	A-33
<b>Stainless Steel Specifications</b> .....	A-47
<b>Studs, Threaded</b> .....	A-6
<b>T</b>	
<b>Tap Drill Guide</b> .....	A-49
<b>Tapping Screws</b>	
Flat Head.....	A-23
Oval Head.....	A-25
Pan Head.....	A-26
<b>Thumb Screws</b> .....	A-29
<b>Tightening Torque–Bolts, Nuts &amp; Screws</b> .....	A-2
<b>W</b>	
<b>Washers</b>	
External Tooth Lock.....	A-13
Internal Tooth Lock.....	A-13
Internal/External Tooth Lock.....	A-13
SAE Flat.....	A-11
Split Lock.....	A-12
USS Flat.....	A-11
<b>Wood Screws</b>	
Flat head.....	A-23
Oval Head.....	A-25
Round Head.....	A-27

See Technical Pages A-1 through A-50.



Office No.02, 1st Floor, Shreeji Plaza, CHS Tata Road  
No 02, Opera House, Charni Road Mumbai - 400004



info@adcoforge.com

GST NO : 27AAXCA2226N1Z4



+91-22-6659 5582 / 6659 5581 /  
4602 5379 (15 Lines)



www.adcoforge.com

**A-2**
**TECHNICAL INFORMATION**
**TIGHTENING TORQUE FOR SCREWS, BOLTS AND NUTS**
**TORQUE COEFFICIENTS - K**

Bolt Size	Theoretical <sup>1</sup> K	Measured K (Average)	
		High-Point Torque	Mid-Point Torque
1/4-20	0.210	0.243	0.267
1/4-28	0.205	0.216	0.231
5/16-18	0.210	0.206	0.186
5/16-24	0.205	0.194	0.183
3/8-16	0.204	0.200	0.247
3/8-24	0.198	0.192	0.234
7/16-14	0.205	0.217	0.224
7/16-20	0.200	0.194	0.190
1/2-13	0.201	0.205	0.158
1/2-20	0.195	0.167	0.205
9/16-12	0.198	0.194	0.214
9/16-18	0.193	0.196	0.207
5/8-11	0.199	0.178	0.196
5/8-18	0.193	0.183	0.175
3/4-10	0.194	0.169	0.172
3/4-16	0.189	0.170	0.180
7/8-9	0.194	0.181	0.194
7/8-14	0.189	0.171	0.178
1- 8	0.193	0.188	0.204
1- 14	0.188	0.161	0.167
Average	0.198	0.191	0.201

<sup>1</sup> Computed with coefficient of friction of 0.15 and the dimensions of American National Standard Hex Nuts.

**TORQUE COEFFICIENTS - COMPUTED**

Size	Hex Nut				Hex Cap Screw (Finished Hex Bolt)	Heavy Hex Screw
	K <sub>1</sub>	K <sub>2</sub>	K <sub>3</sub>	K	K	K
1/4-20	0.1055	0.0753	0.0318	0.213	0.213	0.223
1/4-28	0.1055	0.0786	0.0227	0.207	0.207	0.218
5/16-18	0.0993	0.0766	0.0284	0.204	0.204	0.213
5/16-24	0.0993	0.0790	0.0212	0.200	0.200	0.208
3/8-16	0.0950	0.0772	0.0265	0.199	0.199	0.213
3/8-24	0.0950	0.0802	0.0176	0.193	0.193	0.207
7/16-14	0.0980	0.0772	0.0260	0.201	0.196	0.207
7/16-20	0.0980	0.0800	0.0181	0.196	0.190	0.202
1/2-13	0.0950	0.0780	0.0245	0.198	0.198	0.208
1/2-20	0.0950	0.0811	0.0159	0.192	0.192	0.203
9/16-12	0.0970	0.0781	0.0235	0.199	0.195	0.202
9/16-18	0.0970	0.0811	0.0157	0.194	0.191	0.197
5/8-11	0.0950	0.0783	0.0231	0.196	0.196	0.205
5/8-18	0.0950	0.0816	0.0141	0.191	0.191	0.199
3/4-10	0.0950	0.0790	0.0212	0.195	0.195	0.203
3/4-16	0.0950	0.0819	0.0132	0.190	0.190	0.198
7/8-9	0.0950	0.0793	0.0201	0.194	0.194	0.201
7/8-14	0.0950	0.0819	0.0130	0.190	0.190	0.196
1- 8	0.0950	0.0795	0.0199	0.194	0.194	0.200
1- 14	0.0950	0.0826	0.0109	0.189	0.189	0.194
Average	-	-	-	0.197	0.196	0.205

NOTE : K<sub>1</sub> + K<sub>2</sub> + K<sub>3</sub> = K



Office No.02, 1st Floor, Shreeji Plaza, CHS Tata Road  
 No 02, Opera House, Charni Road Mumbai - 400004



info@adcoforge.com

GST NO : 27AAXCA2226N1Z4



+91-22-6659 5582 / 6659 5581 /  
 4602 5379 (15 Lines)







www.adcoforge.com

## TECHNICAL INFORMATION

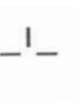
**A-3**

### MECHANICAL REQUIREMENTS FOR BOLTS, SCREWS, STUDS, SEMS, AND U-BOLTS

Grade Designation	Products	Nominal Size Dia, In.	Full-Size Bolts, Screws, Studs, SEMS, Proof Load (Stress), psi	Full Size Bolts, Screws, Studs, SEMS, Tensile Strength (Stress) Min, psi	Machine Test Specimens of Bolts, Screws and Studs Yield Strength (Stress) Min, psi	Machine Test Specimens of Bolts, Screws, and Studs Tensile Strength (Stress) Min, psi	Surface Hardness Rockwell 30N Max	Core Hardness Rockwell Min	Core Hardness Rockwell Max	Grade Identification Marking
1	Bolts, Screws, Studs	1/4 thru 1-1/2	33,000	60,000	36,000	60,000	-	B70	B100	None
2	Bolts, Screws, Studs	1/4 thru 3/4	55,000	74,000	57,000	74,000	-	B80	B100	None
		Over 3/4 thru 1-1/2	33,000	60,000	36,000	60,000	-	B70	B100	
4	Studs	1/4 thru 1-1/2	65,000	115,000	100,000	115,000	-	C22	C32	None
5	Bolts, Screws, Studs	1/4 thru 1	85,000	120,000	92,000	120,000	54.50	C25	C34	
		Over 1 thru 1-1/2	74,000	105,000	81,000	105,000		C19	C30	
5.1	SEMS	No.4 thru 5/8	85,000	120,000	-	-	59.5	C25	C40	
5.2	Bolts, Screws	1/4 thru 1	85,000	120,000	92,000	120,000	56	C26	C36	
8	Bolts, Screws, Studs	1/4 thru 1-1/2	120,000	150,000	130,000	150,000	58.6	C33	C39	
8.1	Studs	1/4 thru 1-1/2	120,000	150,000	130,000	150,000	58.6	C33	C39	None
8.2	Bolts, Screws	1/4 thru 1	120,000	150,000	130,000	150,000	58.6	C33	C39	



## HEAT-TREATED ALLOY STUDS, BOLTS AND THREADED BARS

**Chemical Composition, heat-treated, alloy steel studs**

Elements	A354 Grades BC, BD		A193 Grade B7	
	† See note below		Chromium-Molybdenum (AISI 4140, 4142, 4145)	
	Range Percent	Check variation over percent	Range Percent	Check variation over or under percent
Carbon	–	–	• 0.38-0.48	0.02
Manganese	–	–	0.75-1.00	0.04
Phosphorus, max	0.04	0.005	0.04	0.005 over
Sulphur, max	0.04	0.005	0.04	0.005 over
Silicon	–	–	0.20-0.35	0.02
Chromium	–	–	0.80-1.10	0.05
Molybdenum	–	–	0.15-0.25	0.02

**Tensile Requirements, heat-treated, alloy steel studs**

Grade	Diameter Inches	Min tempering temp F	Tensile strength min psi	Yield point min psi	Elongation in 2" min pct	Reduction of area min pct
A354 Grade BC	2 1/2" and under	850	125,000	109,000	16	50
	Over 2 1/2" to 4" incl	850	115,000	99,000	16	45
A354 Grade BD	1 1/2" and under	850	150,000	125,000	14	35
A193 Grade B7 Chromium-Molybdenum	2 1/2" and under	1100	125,000	105,000	16	50
	Over 2 1/2" to 4" incl	1100	115,000	95,000	16	50
	Over 4" to 7" incl	1100	100,000	75,000	18	50
A193 Grade B16 Chromium-Molybdenum-Vanadium	2 1/2" and under	1200	125,000	105,000	18	50
	Over 2 1/2" to 4" incl	1200	110,000	95,000	17	45
	Over 4" to 7" incl	1200	100,000	85,000	16	45
A320 Grade L7 Chromium-Molybdenum	2 1/2" and under	–	125,000	105,000	16	50
A320 Grade L43 Nickel-Chromium-Molybdenum	4" and under	–	125,000	105,000	16	50

Elements	A193 Grade B16 Chromium-Molybdenum-Vanadium	
	Range Percent	Check variation over or under percent
Carbon	0.35-0.44	0.02
Manganese	0.45-0.70	0.03
Phosphorus, max	0.04	0.005 over
Sulphur, max	0.04	0.005 over
Silicon	0.20-0.35	0.02
Chromium	0.80-1.15	0.05
Molybdenum	0.50-0.65	0.03
Vanadium	0.25-0.35	0.03

Elements	A320 Grade L7 Chromium-Molybdenum (AISI 4140, 4142, 4145)		A320 Grade L43 Nickel-Chromium-Molybdenum (AISI 4340)	
	Range Percent	Check variation over or under percent	Range Percent	Check variation over or under percent
	Carbon	• 0.38-0.48	0.02	0.38-0.43
Manganese	0.75-1.00	0.04	0.60-0.85	0.03
Phosphorus, max	0.04	0.005 over	0.04	0.005 over
Sulphur, max	0.04	0.005 over	0.04	0.005 over
Silicon	0.20-0.35	0.02	0.20-0.35	0.02
Nickel	–	–	1.65-2.00	0.05
Chromium	0.80-1.10	0.05	0.70-0.90	0.03
Molybdenum	0.15-0.25	0.02	0.20-0.30	0.02

• For bar sizes over 3 1/2" to 4" inclusive, the carbon content may be 0.50 pct. max.

† Any alloy steel capable of meeting the tensile requirements of specification A354 may be used.

Commonly used are the following grades of heat-treated alloy steel for high pressure or extreme temperature service in diameters of 1/2" to 2", inclusive. Other grades and other diameters are available on special order.

ASTM A354, Grades BC and BD– heat-treated alloy steels for applications at normal atmospheric temperatures where high strength is required.

ASTM A193, Grade B7– a heat-treated chromium-molybdenum steel widely used for medium high temperature service.

ASTM A193, Grade B16– a heat-treated chromium molybdenum-vanadium steel for high-pressure, high-temperature service.

ASTM A320, Grade L7– This grade is intended for low-temperature service down to minus 150°F and has a minimum Charpy impact value of 15 ft-lb at this temperature. Sizes 2 1/2" and under.

ASTM A320, Grade L43– The same properties offered by Grade L7 in sizes up to 2 1/2" are obtainable up to 4" in Grade L43.

Heat-treated alloy steel bolts and threaded bars are also available from Bethlehem in the grades listed above-bolts in diameters of 3/8" to 1 1/4", inclusive; bars in diameters of 1/2" to 2", inclusive. These are available only on special order.



# TECHNICAL INFORMATION

A-5

## HIGH-STRENGTH STRUCTURAL BOLTS, NUTS AND WASHERS

### Bolt Dimensional Standards ANSI B18.21

Nominal Size of Basic Bolt Dia.	E		F			G		H			R		L <sub>T</sub> (Ref)	Y (Ref)	Runout of Bearing Surface FIR	
	Body Dia.		Width Across Flats			Width Across Corners		Height			Radius of Fillet		Thread Length	Transition Thread Length		
	Max	Min	Basic	Max	Min	Max	Min	Basic	Max	Min	Max	Min	Basic	Max		
1/2	0.5000	0.515	0.482	7/8	0.875	0.850	1.010	0.969	5/16	0.323	0.302	0.031	0.009	1.00	0.19	0.016
5/8	0.6250	0.642	0.605	1 1/16	1.062	1.031	1.227	1.175	25/64	0.403	0.378	0.062	0.021	1.25	0.22	0.019
3/4	0.7500	0.768	0.729	1 1/4	1.250	1.212	1.443	1.383	15/32	0.483	0.455	0.062	0.021	1.38	0.25	0.022
7/8	0.8750	0.895	0.852	1 7/16	1.438	1.394	1.660	1.589	35/64	0.563	0.531	0.062	0.031	1.50	0.28	0.025
1	1.0000	1.022	0.976	1 5/8	1.625	1.575	1.876	1.796	35/64	0.627	0.591	0.093	0.062	1.75	0.31	0.028
1 1/8	1.1250	1.149	1.098	1 13/16	1.812	1.756	2.093	2.002	11/16	0.718	0.658	0.093	0.062	2.00	0.34	0.032
1 1/4	1.2500	1.277	1.223	2	2.000	1.938	2.309	2.209	25/32	0.813	0.749	0.093	0.062	2.00	0.38	0.035
1 3/8	1.3750	1.404	1.345	2 3/16	2.188	2.119	2.526	2.416	27/32	0.878	0.810	0.093	0.062	2.25	0.44	0.038
1 1/2	1.5000	1.531	1.470	2 3/8	2.375	2.300	2.742	2.622	15/16	0.974	0.902	0.093	0.062	2.25	0.44	0.041

### Washer Dimensions

Bolt Size E	Circular Washers				Square or Rectangular Beveled Washers for American Standard Beams and Channels		
	Nominal Outside Diameter	Nominal Diameter Of Hole	Thickness		Minimum Side Dimension	Mean Thickness	Slope or Taper in Thickness
			Min	Max			
1/2	1 1/16	17/32	0.097	0.177	1 3/4	5/16	1.6
5/8	1 1/4	11/16	0.122	0.177	1 3/4	5/16	1.6
3/4	1 1/2	13/16	0.122	0.177	1 3/4	5/16	1.6
7/8	1 3/4	15/16	0.136	0.177	1 3/4	5/16	1.6
1	2	1 1/8	0.136	0.177	1 3/4	5/16	1.6
1 1/8	2 1/4	1 1/4	0.136	0.177	2 1/4	5/16	1.6
1 1/4	2 1/2	1 3/8	0.136	0.177	2 1/4	5/16	1.6
1 3/8	2 3/4	1 1/2	0.136	0.177	2 1/4	5/16	1.6
1 1/2	3	1 5/8	0.136	0.177	2 1/4	5/16	1.6

### Washer Dimensions Tolerance (inches)

Dimension	Washer Size To 1 1/2 In. Nominal Bolt Size, Incl.
	Nominal diameter of hole
Nominal outside dimensions	-1/32: + 1/4
Flatness: max. deviation from straight edge placed on "cut" side shall not exceed	0.01
Butt shall not project above immediately adjacent washer surface more than	0.01

### Nut Dimensions

Nut Size In Inches	Inches	
	Heavy Hex Nuts	
	Width across flats F	Height, G
1/2	7/8	21/64
5/8	1 1/16	35/64
3/4	1 5/16	47/64
7/8	1 7/16	55/64
1	1 5/8	63/64
1 1/8	1 13/16	1 7/64
1 1/4	2	1 7/32
1 3/8	2 3/16	1 11/32
1 1/2	2 3/8	1 15/32



**TYPES OF STUDS**

**CONTINUOUS THREAD STUDS**

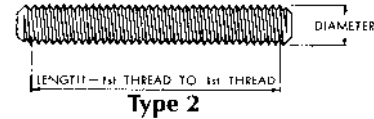
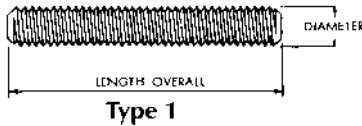

Continuous-thread studs are threaded from end to end and are often used for flange bolting with two nuts applied.

Type 1—General purpose. The length of this type is measured from end to end. Threads are UNRC-2A.

Type 2—Studs for temperature-pressure piping. These studs are made to the dimensional standard requirements of ANS B16.5 and have a length measurement requirement different from all other studs, i.e., the length is measured from first thread to first thread, exclusive of points. Points are flat and chamfered. Threads are UNRC-2A for all sizes 1" and under and 8UNR-2A for all sizes over 1".

**TAP-END STUDS**

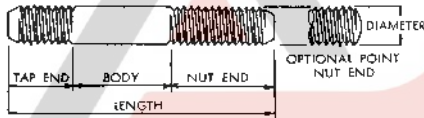

**DOUBLE-END STUDS**

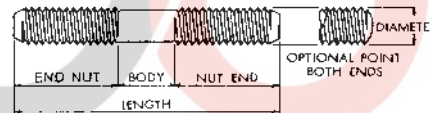

Tap-end studs have a short thread on one end called the tap end which is threaded to a Class NC5 or Class UNRC-3A fit. This end is for screwing into a tapped hole. The other or nut end is threaded with a Class UNRC-2A fit. Length of the stud is measured overall. The tap end has a chamfered point, but the nut end may have either a chamfered or round point, at the manufacturer's option. Tap-end studs are available in four types, as follows:

- Type 1—Unfinished, have a full diameter but no standard body tolerances.
- Type 2—Finished, having either an undersize body with rolled threads or a full-size body with cut threads, at the manufacturer's option. The body portion will be finished to a minimum Class 2A pitch diameter or maximum basic major diameter of the nut-end thread.
- Type 3—Finished full-body, having tolerances equal to that on major diameter of Class 2A threads.
- Type 4—Finished close-body, milled or ground to tolerances specified by the user.

Double-end studs have equal-length threads on each end to accommodate a nut and are threaded to a Class 2A fit. Length of stud is measured overall. Both ends have chamfered points, but round points may be furnished on either or both ends at the manufacturer's option. This style is furnished in the same four types listed for tap-end studs. Double-end studs are used for flange bolting or other applications where torquing from both ends is necessary or desirable.

Most steel grades not heat treated or quenched and tempered can be furnished on special order for production quantities. Only the Type 2 continuous thread studs made to specification ASTM A193 grade B7 are stocked in a full range of sizes.





## TECHNICAL INFORMATION

A-7

### HEX NUT MARKINGS AND PROPERTIES

#### ASTM A194

#### Grade 2, 2H, 4 and 7 (Mechanical Properties) AN Standard B18.2.2 (Dimensions)

For high-temperature, high-pressure in combination with alloy studs and bolts.

These nuts are tapped UNC-2B in sizes of 1" and under or BUN-2B over 1".

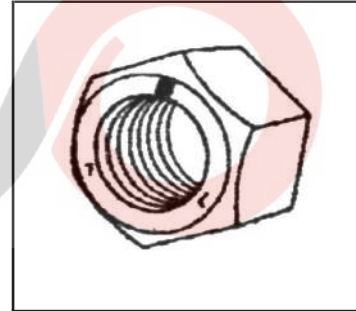
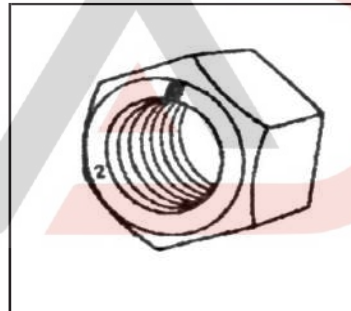
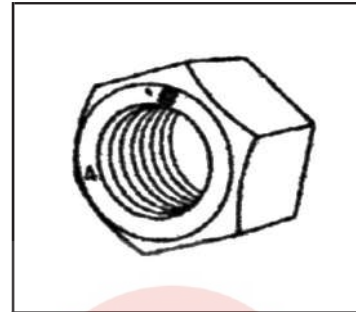
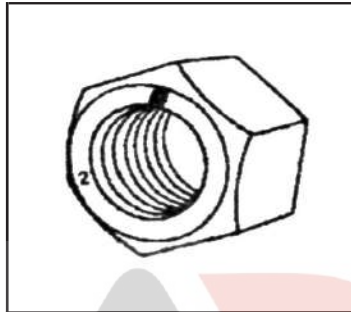

#### ASTM A194 - GRADE 2

Treated nuts suitable for moderate temperature and pressure conditions.

#### ASTM A194 - GRADE 2H

Quenched nuts suitable for high-temperature and high-pressure conditions.

#### ASTM A194 - GRADES 4 and 7

Heat-treated carbon-molybdenum and chromium molybdenum steel nuts suitable for severe temperature and pressure conditions.

Chemical Composition							
Grade	C	Mn	P	S	Si	Mo	Cr
2 and 2H	0.40	-	0.04	0.05	-	-	-
	min		max	max			
4	0.40	0.70	0.035	0.04	0.20	0.20	-
	to 0.50	to 0.90	max	max	to 0.35	to 0.30	
7	0.38	0.75	0.04	0.04	0.20	0.15	0.80
	to 0.48	to 1.00	max	max	to 0.35	to 0.25	to 1.10

Hardness Requirements			
Grade	Brinell	Rockwell B	Rockwell C
2	159 to 352	84 min.	-
2H	248 to 352	-	24 to 38
4 and 7	248 to 352	-	24 to 38

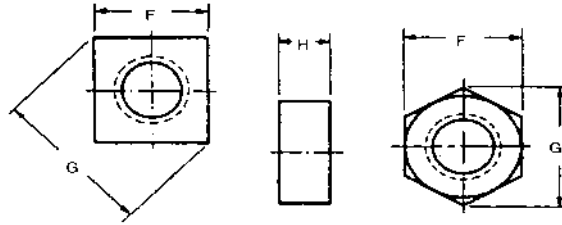

**SQUARE AND HEX MACHINE SCREW NUTS**

Nominal Size or Basic Thread Diameter		F			G		G <sub>1</sub>		H	
		Width Across Flats			Width Across Corners				Thickness	
		Basic	Max	Min	Square		Hex			
					Max	Min	Max	Min	Max	Min
2	0.0860	3/16	0.188	0.180	0.265	0.247	0.217	0.205	0.066	0.057
3	0.0990	3/16	0.188	0.180	0.265	0.247	0.217	0.205	0.066	0.057
4	0.1120	1/4	0.250	0.241	0.354	0.331	0.289	0.275	0.098	0.087
5	0.1250	5/16	0.312	0.302	0.442	0.415	0.361	0.344	0.114	0.102
6	0.1380	5/16	0.312	0.302	0.442	0.415	0.361	0.344	0.114	0.102
8	0.1640	11/32	0.344	0.332	0.486	0.456	0.397	0.378	0.130	0.117
10	0.1900	3/8	0.375	0.362	0.530	0.497	0.433	0.413	0.130	0.117
12	0.2160	7/16	0.438	0.423	0.619	0.581	0.505	0.482	0.161	0.148
1/4	0.2500	7/16	0.438	0.423	0.619	0.581	0.505	0.482	0.193	0.178
5/16	0.3125	9/16	0.562	0.545	0.795	0.748	0.650	0.621	0.225	0.208
3/8	0.3750	5/8	0.625	0.607	0.884	0.833	0.722	0.692	0.257	0.239

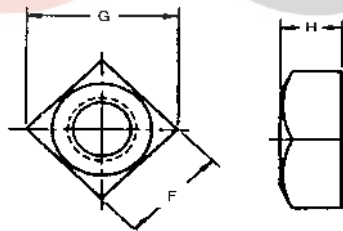
**REGULAR SQUARE NUTS**

Nominal Size or Basic Major Thread Diameter		F			G		H		
		Width Across Flats			Width Across Corners		Thickness		
		Basic	Max	Min	Max	Min	Basic	Max	Min
1/4	0.2500	7/16	0.438	0.425	0.619	0.584	7/32	0.235	0.203
5/16	0.3125	9/16	0.562	0.547	0.795	0.751	17/64	0.283	0.249
3/8	0.3750	5/8	0.625	0.606	0.884	0.832	21/64	0.346	0.310
7/16	0.4375	3/4	0.750	0.728	1.061	1.000	3/8	0.394	0.356
1/2	0.5000	13/16	0.812	0.788	1.149	1.082	7/16	0.458	0.418
5/8	0.6250	1	1.000	0.969	1.414	1.330	35/64	0.569	0.525
3/4	0.7500	1-1/8	1.125	1.088	1.591	1.494	21/32	0.680	0.632
7/8	0.8750	1-5/16	1.312	1.269	1.856	1.742	49/64	0.792	0.740
1	1.0000	1-1/2	1.500	1.450	2.121	1.991	7/8	0.903	0.847



# TECHNICAL INFORMATION

A-9

## FINISHED HEX NUTS

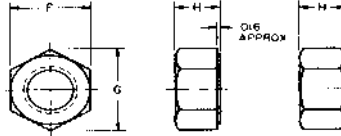

Nominal Size or Basic Major Thread Diameter	F			G		H			
	Width Across Flats			Width Across Corners		Thickness Hex Nuts			
	Basic	Max	Min	Max	Min	Basic	Max	Min	
1/4	0.2500	7/16	0.438	0.428	0.505	0.488	7/32	0.226	0.212
5/16	0.3125	1/2	0.500	0.489	0.577	0.557	17/64	0.273	0.258
3/8	0.3750	9/16	0.562	0.551	0.650	0.628	21/64	0.337	0.320
7/16	0.4375	11/16	0.688	0.675	0.794	0.768	3/8	0.385	0.365
1/2	0.5000	3/4	0.750	0.736	0.866	0.840	7/16	0.448	0.427
9/16	0.5625	7/8	0.875	0.861	1.010	0.982	31/64	0.496	0.473
5/8	0.6250	15/16	0.938	0.922	1.083	1.051	35/64	0.559	0.535
3/4	0.7500	1 1/8	1.125	1.088	1.299	1.240	41/64	0.665	0.617
7/8	0.8750	1 5/16	1.312	1.269	1.516	1.447	3/4	0.776	0.724
1	1.0000	1 1/2	1.500	1.450	1.732	1.653	55/64	0.887	0.831
1 1/8	1.1250	1 11/16	1.688	1.631	1.949	1.859	31/32	0.999	0.939
1 1/4	1.2500	1 7/8	1.875	1.812	2.165	2.066	1 1/16	1.094	1.030
1 3/8	1.3750	2 1/16	2.062	1.994	2.382	2.273	1 11/64	1.206	1.138
1 1/2	1.5000	2 1/4	2.250	2.175	2.598	2.480	1 9/32	1.317	1.245

## HEAVY HEX NUTS

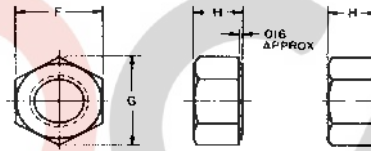

Nominal Size or Basic Major Thread Diameter	F			G		H			
	Width Across Flats			Width Across Corners		Thickness Heavy Hex Nuts			
	Basic	Max	Min	Max	Min	Basic	Max	Min	
1/4	0.2500	1/2	0.500	0.488	0.577	0.556	15/64	0.250	0.218
5/16	0.3125	9/16	0.562	0.546	0.650	0.622	19/64	0.314	0.280
3/8	0.3750	11/16	0.688	0.669	0.794	0.763	23/64	0.377	0.341
7/16	0.4375	3/4	0.750	0.728	0.866	0.830	27/64	0.441	0.403
1/2	0.5000	7/8	0.875	0.850	1.010	0.969	31/64	0.504	0.464
9/16	0.5625	15/16	0.938	0.909	1.083	1.037	35/64	0.568	0.526
5/8	0.6250	1 1/16	1.062	1.031	1.227	1.175	39/64	0.631	0.587
3/4	0.7500	1 1/4	1.250	1.212	1.443	1.382	47/64	0.758	0.710
7/8	0.8750	1 7/16	1.438	1.394	1.660	1.589	55/64	0.885	0.833
1	1.0000	1 5/8	1.625	1.575	1.876	1.796	63/64	1.012	0.956
1 1/8	1.1250	1 13/16	1.812	1.756	2.093	2.002	1 7/64	1.139	1.079
1 1/4	1.2500	2	2.000	1.938	2.309	2.209	1 7/32	1.251	1.187
1 3/8	1.3750	2 3/16	2.188	2.119	2.526	2.416	1 11/32	1.378	1.310
1 1/2	1.5000	2 3/8	2.375	2.300	2.742	2.622	1 15/32	1.505	1.433
1 5/8	1.6250	2 9/16	2.562	2.481	2.959	2.828	1 19/32	1.632	1.556
1 3/4	1.7500	2 3/4	2.750	2.662	3.175	3.035	1 23/32	1.759	1.679
1 7/8	1.8750	2 15/16	2.938	2.844	3.392	3.242	1 27/32	1.886	1.802
2	2.0000	3 1/8	3.125	3.025	3.608	3.449	1 31/32	2.013	1.925
2 1/4	2.2500	3 1/2	3.500	3.388	4.041	3.862	2 13/64	2.251	2.155
2 1/2	2.5000	3 7/8	3.875	3.750	4.474	4.275	2 29/64	2.505	2.401
2 3/4	2.7500	4 1/4	4.250	4.112	4.907	4.688	2 45/64	2.759	2.647
3	3.0000	4 5/8	4.625	4.475	5.340	5.102	2 61/64	3.013	2.893
3 1/4	3.2500	5	5.000	4.838	5.774	5.515	3 3/16	3.252	3.124
3 1/2	3.5000	5 3/8	5.375	5.200	6.207	5.928	3 7/16	3.506	3.370
3 3/4	3.7500	5 3/4	5.750	5.562	6.640	6.341	3 11/16	3.760	3.616
4	4.0000	6 1/8	6.125	5.925	7.073	6.755	3 15/16	4.014	3.862



## JAM NUTS - HEX AND HEAVY HEX ASTM A307

Double-chamfered hex nuts are offered with UNC-2B or UNF-2B threads in diameters ranging from 1/4" to 1" inclusive.

Heavy hex jam nuts are available with UNC-2B threads, double-chamfered in diameters of 1/4" to 1" inclusive, or washer-faced in diameters of 1-1/8" to 2" inclusive.

### Hex jam nut dimensions (in.) ANSI B18.2.2

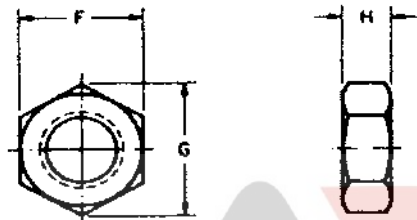

Hex Jam Nut, double-chamfered

Nominal Size or Basic Major Diam of Thread	Width Across Flats F			Width Across Corners G		Thickness Hex Jam Nuts H			
	Basic	Max	Min	Max	Min	Basic	Max	Min	
1/4	0.2500	7/16	0.438	0.428	0.505	0.488	5/32	0.163	0.150
5/16	0.3125	1/2	0.500	0.489	0.577	0.557	3/16	0.195	0.180
3/8	0.3750	9/16	0.562	0.551	0.650	0.628	7/32	0.227	0.210
7/16	0.4375	11/16	0.688	0.675	0.794	0.768	1/4	0.260	0.240
1/2	0.5000	3/4	0.750	0.736	0.866	0.840	5/16	0.323	0.302
9/16	0.5625	7/8	0.875	0.861	1.010	0.982	5/16	0.324	0.301
5/8	0.6250	15/16	0.938	0.922	1.083	1.051	3/8	0.387	0.363
3/4	0.7500	1 1/8	1.125	1.088	1.299	1.240	27/64	0.446	0.398
7/8	0.8750	1 5/16	1.312	1.269	1.516	1.447	31/64	0.510	0.458
1	1.0000	1 1/2	1.500	1.450	1.732	1.853	35/64	0.575	0.518

### Heavy hex jam nut dimensions (in.) ANSI B18.2.2

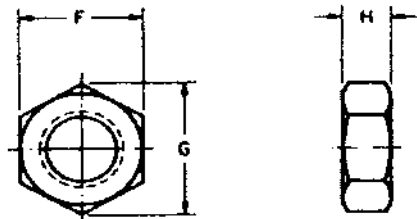

Heavy Hex Jam Nut, washer-faced and double-chamfered

Nominal Size or Basic Major Diam of Thread	Width Across Flats F			Width Across Corners G		Thickness Heavy Hex Jam Nuts H			
	Basic	Max	Min	Max	Min	Basic	Max	Min	
1/4	0.2500	1/2	0.500	0.488	0.577	0.556	11/64	0.188	0.156
5/16	0.3125	9/16	0.562	0.546	0.650	0.622	13/64	0.220	0.186
3/8	0.3750	11/16	0.688	0.669	0.794	0.763	15/64	0.252	0.216
7/16	0.4375	3/4	0.750	0.728	0.866	0.830	17/64	0.285	0.247
1/2	0.5000	7/8	0.875	0.850	1.010	0.969	19/64	0.317	0.277
9/16	0.5625	15/16	0.938	0.909	1.083	1.037	21/64	0.349	0.307
5/8	0.6250	1 1/16	1.062	1.031	1.227	1.175	23/64	0.381	0.337
3/4	0.7500	1 1/4	1.250	1.212	1.443	1.382	27/64	0.446	0.398
7/8	0.8750	1 7/16	1.438	1.394	1.660	1.589	31/64	0.510	0.458
1	1.0000	1 5/8	1.625	1.575	1.876	1.796	35/64	0.575	0.519
1 1/8	1.1250	1 13/16	1.812	1.756	2.093	2.002	39/64	0.639	0.579
1 1/4	1.2500	2	2.000	1.938	2.309	2.209	23/32	0.751	0.687
1 3/8	1.3750	2 3/16	2.188	2.119	2.526	2.416	25/32	0.815	0.747
1 1/2	1.5000	2 3/8	2.375	2.300	2.742	2.622	27/32	0.880	0.808
1 5/8	1.6250	2 9/16	2.562	2.481	2.959	2.828	29/32	0.944	0.868
1 3/4	1.7500	2 3/4	2.750	2.662	3.175	3.035	31/32	1.009	0.929
1 7/8	1.8750	2 15/16	2.938	2.844	3.392	3.242	1 1/16	1.073	0.989
2	2.0000	3 1/8	3.125	3.025	3.608	3.449	1 3/32	1.138	1.050



# TECHNICAL INFORMATION

# A-11

## “K” LOCK NUTS

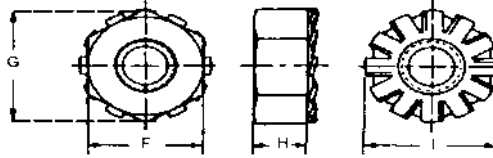

Nominal Size or Basic Thread Diameter	F			G		H		I	
	Width Across Flats			Width Across Corners		Thickness			
	Basic	Max	Min	Max	Min	Max	Min	Ref	
4	0.1120	1/4	0.250	0.241	0.289	0.275	0.098	0.087	0.281
6	0.1380	5/16	0.312	0.302	0.361	0.344	0.114	0.102	0.344
8	0.1640	11/32	0.344	0.332	0.397	0.378	0.130	0.117	0.375
10	0.1900	3/8	0.375	0.362	0.433	0.413	0.130	0.117	0.406
1/4	0.2500	7/16	0.438	0.423	0.505	0.482	0.193	0.178	0.500
5/16	0.3125	1/2	0.500	0.489	0.577	0.557	0.273	0.258	0.578
3/8	0.3750	9/16	0.562	0.551	0.650	0.628	0.385	0.365	0.656

## FLAT WASHERS

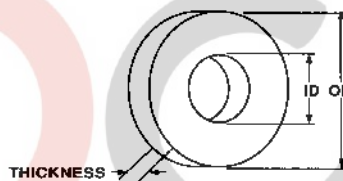

### SAE WASHERS

Bolt Size	Inches		Gauge	Est. Pcs. per 1 lb.	Wt. per M pcs.
	I.D.	O.D.			
#4	1/8	5/16	#21 (1/32)	1650	0.6
#6	5/32	3/8	#18 (3/64)	790	1.26
#8	3/16	7/16	#18 (3/64)	585	1.7
#10	7/32	1/2	#18 (3/64)	435	2.3
#12	1/4	9/16	#16 (1/16)	280	3.7
1/4	9/32	5/8	#16 (1/16)	222	4.5
5/16	11/32	11/16	#16 (1/16)	192	5.2
3/8	13/32	13/16	#16 (1/16)	140	7.2
7/16	15/32	59/64	#16 (1/16)	105	9.5
1/2	17/32	1 1/16	#13 (3/32)	55	18.3
9/16	19/32	1 3/16	#13 (3/32)	43	23.4
5/8	21/32	1 5/16	#13 (3/32)	36	27.7
3/4	13/16	1 1/2	#10 (9/64)	21	47.4
7/8	15/16	1 3/4	#10 (9/64)	16	63
1	1 1/16	2	#10 (9/64)	12	83
1 1/8	1 3/16	2 1/4	#10 (9/64)	9.2	109
1 1/4	1 5/16	2 1/2	#9 (5/32)	6.3	160
1 3/8	1 7/16	2 3/4	#9 (5/32)	5.25	190
1 1/2	1 9/16	3	#9 (5/32)	4.25	240

### USS STANDARD WASHERS

Bolt Size	Inches		Gauge	Est. Pcs. per 1 lb.	Wt. per M pcs.
	I.D.	O.D.			
3/16	1/4	9/16	#18 (3/64)	361	2.8
1/4	5/16	3/4	#16 (1/16)	149	6.7
5/16	3/8	7/8	#14 (5/64)	87	11.5
3/8	7/16	1	#14 (5/64)	67	14.9
7/16	1/2	1 1/4	#14 (5/64)	41	24.4
1/2	9/16	1 3/8	#12 (7/64)	26	38.5
9/16	5/8	1 1/2	#12 (7/64)	22	45.5
5/8	11/16	1 3/4	#10 (9/64)	13	77
3/4	13/16	2	#9 (5/32)	9.1	110
7/8	15/16	2 1/4	#8 (11/64)	6.5	153
1	1 1/16	2 1/2	#8 (11/64)	5.3	188
1 1/8	1 1/4	2 3/4	#8 (11/64)	4.5	220
1 1/4	1 3/8	3	#8 (11/64)	3.8	260
1 3/8	1 1/2	3 1/4	#7 (3/16)	3.0	333
1 1/2	1 5/8	3 1/2	#7 (3/16)	2.6	385
1 5/8	1 3/4	3 3/4	#7 (3/16)	2.3	448
1 3/4	1 7/8	4	#7 (3/16)	2.0	500
1 7/8	2	4 1/4	#7 (3/16)	1.8	569
2	2 1/8	4 1/2	#7 (3/16)	1.6	630
2 1/4	2 3/8	4 3/4	#5 (7/32)	1.2	826

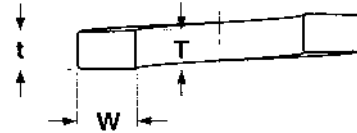
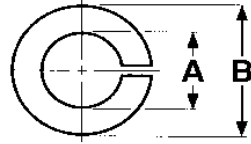

**A-12**
**TECHNICAL INFORMATION**
**SPLIT LOCK WASHERS**
**MEDIUM SPLIT  
HELICAL SPRING  
LOCK WASHERS**

Nominal Washer Size	A		B	W	$T^2t$ 2	
	Inside Diameter		Outside Diameter	Washer Section		
	Min	Max	Max <sup>2</sup>	Width Min	Thickness Min	
2	0.086	0.088	0.094	0.172	0.035	0.020
4	0.112	0.115	0.121	0.209	0.040	0.025
5	0.125	0.128	0.134	0.236	0.047	0.031
6	0.138	0.141	0.148	0.250	0.047	0.031
8	0.164	0.168	0.175	0.293	0.055	0.040
10	0.190	0.194	0.202	0.334	0.062	0.047
12	0.216	0.221	0.229	0.377	0.070	0.056
1/4	0.250	0.255	0.263	0.489	0.109	0.062
5/16	0.312	0.318	0.328	0.586	0.125	0.078
3/8	0.375	0.382	0.393	0.683	0.141	0.094
7/16	0.438	0.446	0.459	0.779	0.156	0.109
1/2	0.500	0.509	0.523	0.873	0.171	0.125
9/16	0.562	0.572	0.587	0.971	0.188	0.141
5/8	0.625	0.636	0.653	1.079	0.203	0.156
3/4	0.750	0.763	0.783	1.271	0.234	0.188
7/8	0.875	0.890	0.912	1.464	0.266	0.219
1	1.000	1.017	1.042	1.661	0.297	0.250
1 1/6	1.062	1.080	1.107	1.756	0.312	0.266
1 1/8	1.125	1.144	1.172	1.853	0.328	0.281
1 3/16	1.188	1.208	1.237	1.950	0.344	0.297
1 1/4	1.250	1.271	1.302	2.045	0.359	0.312
1 1/2	1.500	1.525	1.561	2.430	0.422	0.375

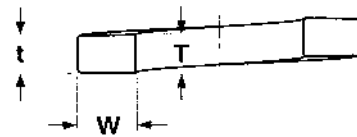
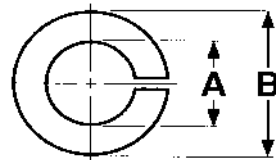
**HI-COLLAR  
HELICAL SPRING  
LOCK WASHERS**

Nominal Washer Size	A		B	W	$T^2t$ 2	
	Inside Diameter		Outside Diameter	Washer Section		
	Min	Max	Max <sup>2</sup>	Width Min	Thickness Min	
4	0.112	0.115	0.121	0.173	0.022	0.022
6	0.138	0.141	0.148	0.216	0.030	0.030
8	0.164	0.168	0.175	0.267	0.042	0.047
10	0.190	0.194	0.202	0.294	0.042	0.047
1/4	0.250	0.255	0.263	0.365	0.047	0.078
5/16	0.312	0.318	0.328	0.460	0.062	0.093
3/8	0.375	0.382	0.393	0.553	0.076	0.125



# TECHNICAL INFORMATION

# A-13

## INTERNAL TOOTH LOCK WASHERS

Nominal Washer Size	A		B		C		
	Inside Diameter		Outside Diameter		Thickness		
	Min	Max	Max	Min	Max	Min	
No. 2	0.086	0.089	0.095	0.200	0.175	0.015	0.010
No. 4	0.112	0.115	0.123	0.270	0.255	0.019	0.015
No. 6	0.138	0.141	0.150	0.295	0.275	0.021	0.017
No. 8	0.164	0.168	0.176	0.340	0.325	0.023	0.018
No. 10	0.190	0.195	0.204	0.381	0.365	0.025	0.020
No. 12	0.216	0.221	0.231	0.410	0.394	0.025	0.020
1/4	0.250	0.256	0.267	0.478	0.460	0.028	0.023
5/16	0.312	0.320	0.332	0.610	0.594	0.034	0.028
3/8	0.375	0.384	0.398	0.692	0.670	0.040	0.032
7/16	0.438	0.448	0.464	0.789	0.740	0.040	0.032
1/2	0.500	0.512	0.530	0.900	0.867	0.045	0.037
5/8	0.625	0.640	0.663	1.071	1.045	0.050	0.042

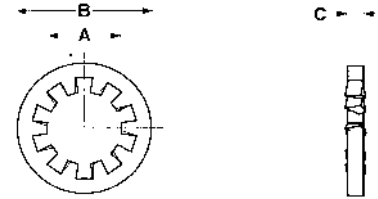

## EXTERNAL TOOTH LOCK WASHERS

Nominal Washer Size	A		B		C		
	Inside Diameter		Outside Diameter		Thickness		
	Min	Max	Max	Min	Max	Min	
No. 4	0.112	0.115	0.123	0.260	0.245	0.019	0.015
No. 6	0.138	0.141	0.150	0.320	0.305	0.022	0.016
No. 8	0.164	0.168	0.176	0.381	0.365	0.023	0.018
No. 10	0.190	0.195	0.204	0.410	0.395	0.025	0.020
No. 12	0.216	0.221	0.231	0.475	0.460	0.028	0.023
1/4	0.250	0.256	0.267	0.510	0.494	0.028	0.023
5/16	0.312	0.320	0.332	0.610	0.588	0.034	0.028
3/8	0.375	0.384	0.398	0.694	0.670	0.040	0.032
7/16	0.438	0.448	0.464	0.760	0.740	0.040	0.032
1/2	0.500	0.513	0.530	0.900	0.880	0.045	0.037
5/8	0.625	0.641	0.663	1.070	1.045	0.050	0.042

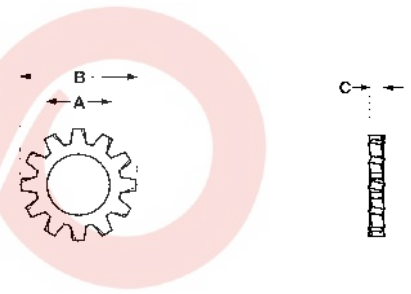





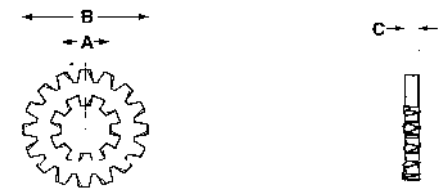



## COMBINATION INTERNAL-EXTERNAL TOOTH LOCK WASHERS

Nominal Washer Size	A		B		C		
	Inside Diameter		Outside Diameter		Thickness		
	Max	Min	Max	Min	Max	Min	
6	0.138	0.150	0.141	0.510	0.495	0.028	0.023
8	0.164	0.176	0.168	0.506	0.494	0.028	0.023
8	0.164	0.176	0.168	0.610	0.580	0.034	0.028
10	0.190	0.204	0.195	0.610	0.580	0.034	0.028
1/4	0.250	0.267	0.256	0.760	0.725	0.040	0.032
5/16	0.312	0.332	0.320	0.900	0.865	0.040	0.032
3/8	0.375	0.398	0.384	0.985	0.965	0.045	0.037
7/16	0.438	0.464	0.448	1.070	1.045	0.050	0.042
1/2	0.500	0.530	0.512	1.260	1.220	0.055	0.047
5/8	0.625	0.663	0.640	1.410	1.380	0.060	0.052



**IDENTIFICATION MARKINGS ON BOLT HEADS**
**ASTM and SAE Standards  
 Specifications, Proof Loads, Tensile Strengths**

Grade Marking	Specification	Material	Bolt and Screw Size In	Proof Load psi	Tensile Strength min psi
	SAE-J429 Grade 1	Low or Medium Carbon Steel	1/4 thru 1 1/2	33,000	60,000
	ASTM-A307		1/4 thru 4		60,000
	SAE-J429 Grade 2	Low or Medium Carbon Steel	1/4 thru 1/4 Over 3/4 thru 1 1/2	55,000 33,000	74,000 60,000
	SAE-J429 Grade 5	Medium Carbon Steel Quenched and Tempered	1/4 thru 1 Over 1 thru 1 1/4	85,000 74,000	120,000 105,000
	ASTM-A449		1/4 thru 1 Over 1 thru 1 1/2	85,000 74,000	120,000 105,000
			Over 1 1/2 thru 3	55,000	90,000
	*ASTM-A325 Type 1	Medium Carbon Steel Quenched and Tempered	1/2 thru 1 1/2 Over 1 thru 1 1/2	85,000 74,000	120,000 105,000
	*ASTM-A32b Type 2	Low Carbon Martensite Steel Quenched and Tempered	1/2 thru 1	85,000	120,000
	ASTM-A325 Type 3	Weather Resistant Steel Quenched and Tempered	1 1/8 thru 1 1/2	74,000	105,000
			1/2 thru 1	85,000	120,000
	ASTM-A354 Grade BB	Low Alloy Steel Quenched and Tempered	1/4 thru 2 1/2 Over 2 1/4 thru 4	80,000 75,000	105,000 100,000
	ASTM-A354 Grade BC	Low Alloy Steel Quenched and Tempered	1/4 thru 4 Over 2 1/2 thru 4	105,000 95,000	125,000 115,000
	SAE-J429 GRADE B	Medium Carbon Alloy Steel Quenched and Tempered	1/4 thru 1 1/4	120,000	150,000
	ASTM-A354 Grade BD	Low Alloy Steel Quenched and Tempered			
	ASTM-A490	Alloy Steel Quenched and Tempered	1/2 thru 1 1/2	120,000	150,000

\* Radial Lines on Type 1 bolts are optional to manufacturer. On Type 2 bolts radial lines 60 degrees apart are required.  
 Bolthead markings include manufacturers identity symbols.





# TECHNICAL INFORMATION

# A-15

## STRUCTURAL BOLTS - HIGH STRENGTH GRIP RANGES FOR HIGH STRENGTH STRUCTURAL BOLTS

Nom Bolt Dia and Thds per Inch Nom Bolt Length Inch	1/2-13		5/8-11		3/4-10		7/8-9		1-8		1-1/8-7		1-1/4-7		1-3/8-6		1-1/2-6	
	Grip Range, Inch																	
	Min	Max	Min	Max	Min	Max	Min	Max	Min	Max	Min	Max	Min	Max	Min	Max	Min	Max
1.25	-	-	-	-	-	-	-	-	-	-	-	-	-	-	-	-	-	-
1.50	0.55	0.79	-	-	-	-	-	-	-	-	-	-	-	-	-	-	-	-
1.75	0.80	1.04	0.56	0.89	-	-	-	-	-	-	-	-	-	-	-	-	-	-
2.00	1.05	1.29	0.81	1.14	0.69	0.94	-	-	-	-	-	-	-	-	-	-	-	-
2.25	1.30	1.54	1.06	1.39	0.94	1.19	0.82	1.09	-	-	-	-	-	-	-	-	-	-
2.50	1.55	1.79	1.31	1.64	1.19	1.44	1.07	1.34	-	-	-	-	-	-	-	-	-	-
2.75	1.80	2.04	1.56	1.89	1.44	1.69	1.32	1.59	1.08	1.47	-	-	-	-	-	-	-	-
3.00	2.05	2.29	1.81	2.14	1.69	1.94	1.57	1.84	1.33	1.72	1.10	1.53	1.10	1.42	-	-	-	-
3.25	2.30	2.54	2.06	2.39	1.94	2.19	1.82	2.09	1.58	1.97	1.35	1.78	1.35	1.67	1.11	1.54	1.11	1.41
3.50	2.55	2.79	2.31	2.64	2.19	2.44	2.07	2.34	1.83	2.22	1.60	2.03	1.60	1.92	1.36	1.79	1.36	1.66
3.75	2.80	3.04	2.56	2.89	2.44	2.69	2.32	2.59	2.08	2.47	1.85	2.28	1.85	2.17	1.61	2.04	1.61	1.91
4.00	3.05	3.29	2.81	3.14	2.69	2.94	2.57	2.84	2.33	2.72	2.10	2.53	2.10	2.42	1.86	2.29	1.86	2.16
4.25	3.30	3.54	3.06	3.39	2.94	3.19	2.82	3.09	2.58	2.97	2.35	2.78	2.35	2.67	2.11	2.54	2.11	2.41
4.50	3.55	3.79	3.31	3.64	3.19	3.44	3.07	3.34	2.83	3.22	2.60	3.03	2.60	2.92	2.36	2.79	2.36	2.66
4.75	3.80	4.04	3.56	3.89	3.44	3.69	3.32	3.59	3.08	3.47	2.85	3.28	2.85	3.17	2.61	3.04	2.61	2.91
5.00	4.05	4.29	3.81	4.14	3.69	3.94	3.57	3.84	3.33	3.72	3.10	3.53	3.10	3.42	2.86	3.29	2.86	3.16
5.25	4.30	4.54	4.06	4.39	3.94	4.19	3.82	4.09	3.58	3.97	3.35	3.78	3.35	3.67	3.11	3.54	3.11	3.41
5.50	4.55	4.79	4.31	4.64	4.19	4.44	4.07	4.34	3.83	4.22	3.60	4.03	3.60	3.92	3.36	3.79	3.36	3.66
5.75	4.80	5.04	4.56	4.89	4.44	4.69	4.32	4.59	4.08	4.47	3.85	4.28	3.85	4.17	3.61	4.04	3.61	3.91
6.00	5.05	5.29	4.81	5.14	4.69	4.94	4.57	4.84	4.33	4.72	4.10	4.53	4.10	4.42	3.86	4.29	3.86	4.16
6.25	-	-	-	-	4.94	5.19	4.82	5.03	4.58	4.91	4.35	4.78	4.35	4.67	4.11	4.54	4.11	4.41
6.50	-	-	-	-	5.19	5.44	5.07	5.28	4.83	5.16	4.60	5.03	4.60	4.92	4.36	4.79	4.36	4.66
6.75	-	-	-	-	5.44	5.69	5.32	5.53	5.08	5.41	4.85	5.28	4.85	5.17	4.61	5.04	4.61	4.91
7.00	-	-	-	-	5.69	5.94	5.57	5.78	5.33	5.66	5.10	5.53	5.10	5.42	4.86	5.29	4.86	5.16
7.25	-	-	-	-	5.94	6.19	5.82	6.03	5.58	5.91	5.35	5.78	5.35	5.67	5.11	5.54	5.11	5.41
7.50	-	-	-	-	6.19	6.44	6.07	6.28	5.83	6.16	5.60	6.03	5.60	5.92	5.36	5.79	5.36	5.66
7.75	-	-	-	-	6.44	6.69	6.32	6.53	6.08	6.41	5.85	6.28	5.85	6.17	5.61	6.04	5.61	5.91
8.00	-	-	-	-	6.69	6.94	6.57	6.78	6.33	6.66	6.10	6.53	6.10	6.42	5.86	6.29	5.86	6.16

### A325 BOLTS

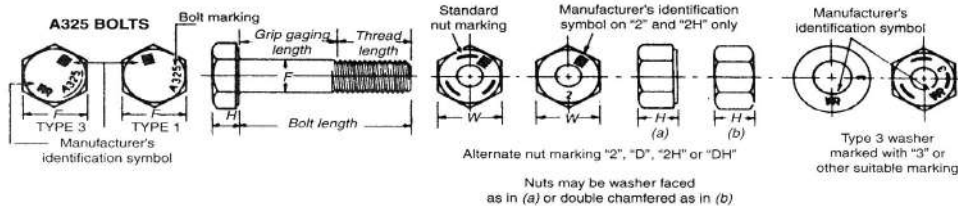

### A490 BOLTS

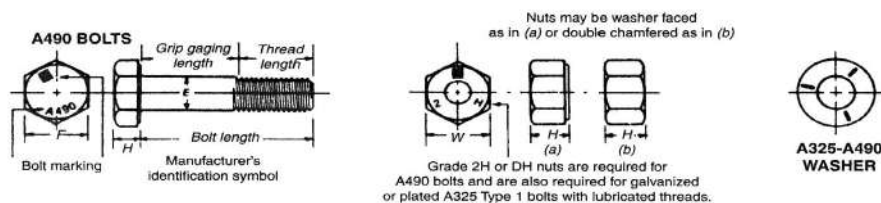

# A-16

# TECHNICAL INFORMATION

## HEX HEAD CAP SCREWS

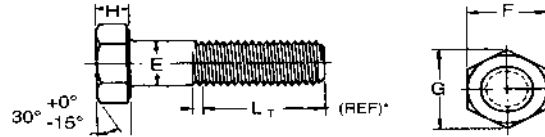

Nominal Size or Basic Product Dia.	E		F			G		H			L <sub>T</sub> (Ref)	
	Body Diameter		Width Across Flats			Width Across Corners		Height			Thread Length For Screw Lengths	
	Max	Min	Basic	Max	Min	Max	Min	Basic	Max	Min	Less than 6"	More than 6"
1/4	0.2500	0.2450	7/16	0.438	0.428	0.505	0.488	5/32	0.163	0.150	0.750	1.000
5/16	0.3125	0.3065	1/2	0.500	0.489	0.577	0.557	13/64	0.211	0.195	0.875	1.125
3/8	0.3750	0.3690	9/16	0.562	0.551	0.650	0.628	15/64	0.243	0.226	1.000	1.250
7/16	0.4375	0.4305	5/8	0.625	0.612	0.722	0.698	9/32	0.291	0.272	1.125	1.375
1/2	0.5000	0.4930	3/4	0.750	0.736	0.866	0.840	5/16	0.323	0.302	1.250	1.500
9/16	0.5625	0.5545	13/16	0.812	0.798	0.938	0.910	23/64	0.371	0.348	1.375	1.625
5/8	0.6250	0.6170	15/16	0.938	0.922	1.083	1.051	25/64	0.403	0.378	1.500	1.750
3/4	0.7500	0.7410	1 1/8	1.125	1.100	1.299	1.254	15/32	0.483	0.455	1.750	2.000
7/8	0.8750	0.8660	1 5/16	1.312	1.285	1.516	1.465	35/64	0.563	0.531	2.000	2.250
1	1.0000	0.9900	1 1/2	1.500	1.469	1.732	1.675	39/64	0.627	0.591	2.250	2.500
1 1/8	1.1250	1.1140	1 11/16	1.688	1.631	1.949	1.859	11/16	0.718	0.658	2.500	2.750
1 1/4	1.2500	1.2390	1 7/8	1.875	1.812	2.165	2.066	25/32	0.813	0.749	2.750	3.000
1 3/8	1.3750	1.3630	2 1/16	2.062	1.994	2.382	2.273	27/32	0.878	0.810	3.000	3.250
1 1/2	1.5000	1.4880	2 1/4	2.250	2.175	2.598	2.480	15/16	0.974	0.902	3.250	3.500
1 3/4	1.7500	1.7380	2 5/8	2.625	2.538	3.031	2.893	1 3/32	1.134	1.054	3.750	4.000
2	2.0000	1.9880	3	3.000	2.900	3.464	3.306	1 7/32	1.263	1.175	4.250	4.500
2 1/4	2.2500	2.2380	3 3/8	3.375	3.262	3.897	3.719	1 3/8	1.423	1.327	4.750	5.000
2 1/2	2.5000	2.4880	3 3/4	3.750	3.625	4.330	4.133	1 17/32	1.583	1.479	5.250	5.500
2 3/4	2.7500	2.7380	4 1/8	4.125	3.988	4.763	4.546	1 11/16	1.744	1.632	5.750	6.000
3	3.0000	2.9880	4 1/2	4.500	4.350	5.196	4.959	1 7/8	1.935	1.815	6.250	6.500

## HEAVY HEX BOLTS

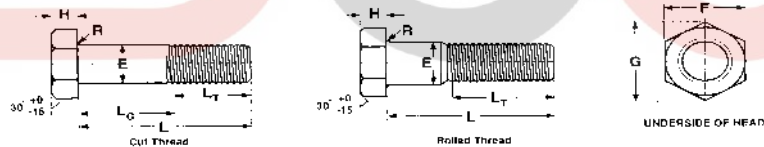

Nominal Size or Basic Product Dia.	E		F			G		H			R		L <sub>T</sub>		
	Body Dia.		Width Across Flats			Width Across Corners		Head Height			Radius of Fillet		Thread Length For Bolt Lengths		
	Max	Min	Basic	Max	Min	Max	Min	Basic	Max	Min	Max	Min	Less Than 6"	More Than 6"	
1/2	0.5000	0.515	0.482	7/8	0.875	0.850	1.010	0.969	11/32	0.364	0.302	0.03	0.01	1.250	1.500
5/8	0.6250	0.642	0.605	1-1/16	1.062	1.031	1.227	1.175	27/64	0.444	0.378	0.06	0.02	1.500	1.750
3/4	0.7500	0.768	0.729	1-1/4	1.250	1.212	1.443	1.383	1/2	0.524	0.455	0.06	0.02	1.750	2.000
7/8	0.8750	0.895	0.852	1-7/16	1.438	1.394	1.660	1.589	37/64	0.604	0.531	0.06	0.02	2.000	2.250
1	1.0000	1.022	0.976	1-5/8	1.625	1.575	1.876	1.796	43/64	0.700	0.591	0.09	0.03	2.250	2.500
1-1/8	1.1250	1.149	1.098	1-13/16	1.812	1.756	2.093	2.002	3/4	0.780	0.658	0.09	0.03	2.500	2.750
1-1/4	1.2500	1.277	1.223	2	2.000	1.938	2.309	2.209	27/32	0.876	0.749	0.09	0.03	2.750	3.000
1-3/8	1.3750	1.404	1.345	2-3/16	2.188	2.119	2.526	2.416	29/32	0.940	0.810	0.09	0.03	3.000	3.250
1-1/2	1.5000	1.531	1.470	2-3/8	2.375	2.300	2.742	2.622	1	1.036	0.902	0.09	0.03	3.250	3.500
1-3/4	1.7500	1.785	1.716	2-3/4	2.750	2.662	3.175	3.035	1-5/32	1.196	1.054	0.12	0.04	3.750	4.000
2	2.0000	2.039	1.964	3-1/8	3.125	3.025	3.608	3.449	1-11/32	1.388	1.175	0.12	0.04	4.250	4.500
2-1/4	2.2500	2.305	2.214	3-1/2	3.500	3.388	4.041	3.862	1-1/2	1.548	1.327	0.19	0.06	4.750	5.000
2-1/2	2.5000	2.559	2.461	3-7/8	3.875	3.750	4.474	4.275	1-21/32	1.708	1.479	0.19	0.06	5.250	5.500
2-3/4	2.7500	2.827	2.711	4-1/4	4.250	4.112	4.907	4.688	1-13/16	1.869	1.632	0.19	0.06	5.750	6.000
3	3.0000	3.081	2.961	4-5/8	4.625	4.475	5.340	5.102	2	2.060	1.815	0.19	0.06	6.250	6.500



Office No.02, 1st Floor, Shreeji Plaza, CHS Tata Road  
No 02, Opera House, Charni Road Mumbai - 400004



+91-22-6659 5582 / 6659 5581 /  
4602 5379 (15 Lines)



info@adcoforge.com

GST NO : 27AAXCA2226N1Z4



www.adcoforge.com

# TECHNICAL INFORMATION

# A-17

## SQUARE HEAD BOLTS

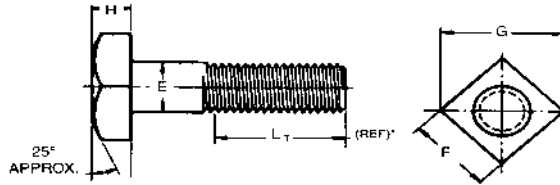

Nominal Size or Basic Bolt Dia.	E		F		G		H			L <sub>T</sub> (Ref)	
	Body Dia	Max	Width Across Flats		Width Across Corners		Height			Thread Length For Bolt Lengths	
			Basic	Max	Min	Max	Min	Basic	Max	Min	Less Than 6"
1/4	0.260	3/8	0.375	0.362	0.530	0.498	11/64	0.188	0.156	0.750	1.000
5/16	0.324	1/2	0.500	0.484	0.707	0.665	13/64	0.220	0.186	0.875	1.125
3/8	0.388	9/16	0.562	0.544	0.795	0.747	1/4	0.268	0.232	1.000	1.250
7/16	0.452	5/8	0.625	0.603	0.884	0.828	19/64	0.316	0.278	1.125	1.375
1/2	0.515	3/4	0.750	0.725	1.061	0.995	21/64	0.348	0.308	1.250	1.500
5/8	0.642	15/16	0.938	0.906	1.326	1.244	27/64	0.444	0.400	1.500	1.750
3/4	0.768	1 1/8	1.125	1.088	1.591	1.494	1/2	0.524	0.476	1.750	2.000
7/8	0.895	1 5/16	1.312	1.269	1.856	1.742	19/32	0.620	0.568	2.000	2.250
1	1.022	1 1/2	1.500	1.450	2.121	1.991	21/32	0.684	0.628	2.250	2.500
1 1/8	1.149	1 11/16	1.688	1.631	2.386	2.239	3/4	0.780	0.720	2.250	2.750
1 1/4	1.277	1 7/8	1.875	1.812	2.652	2.489	27/32	0.876	0.812	2.750	3.000
1 3/8	1.404	2 1/16	2.062	1.994	2.917	2.738	29/32	0.940	0.872	3.000	3.250
1 1/2	1.531	2 1/4	2.250	2.175	3.182	2.986	1	1.036	0.964	3.250	3.500

## HEX HEAD LAG SCREWS

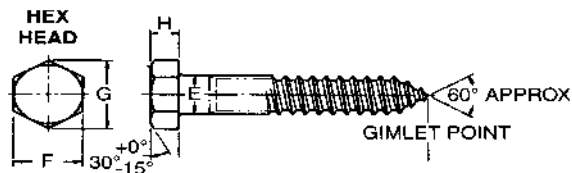

Nominal Size or Basic Product Dia	E		F			G		H			Threads per Inch
	Body or Shoulder Dia.		Width Across Flats			Hex Lag Screws		Height			
	Max	Min	Basic	Max	Min	Max	Min	Basic	Max	Min	
No. 10	0.199	0.178	9/32	0.281	0.271	0.323	0.309	1/8	0.140	0.110	11
1/4	0.260	0.237	3/8	0.375	0.362	-	-	-	-	-	10
1/4 **	0.260	0.237	7/16	0.438	0.425	0.505	0.484	11/64	0.188	0.150	10
5/16	0.324	0.298	1/2	0.500	0.484	0.577	0.552	7/32	0.235	0.195	9
3/8	0.388	0.360	9/16	0.562	0.544	0.650	0.620	1/4	0.268	0.226	7
7/16	0.452	0.421	5/8	0.625	0.603	0.722	0.687	19/64	0.316	0.272	7
1/2	0.515	0.482	3/4	0.750	0.725	0.866	0.826	11/32	0.364	0.302	6
5/8	0.642	0.605	15/16	0.938	0.906	1.083	1.033	27/64	0.444	0.378	5
3/4	0.768	0.729	1 1/8	1.125	1.088	1.299	1.240	1/2	0.524	0.455	4 1/2
7/8	0.895	0.852	1 15/16	1.312	1.269	1.516	1.447	37/64	0.604	0.531	4
1	1.022	0.976	1 1/2	1.500	1.450	1.732	1.653	43/64	0.700	0.591	3 1/2
1 1/8	1.149	1.098	1 11/16	1.688	1.631	1.949	1.859	3/4	0.780	0.658	3 1/4
1 1/4	1.277	1.223	1 7/8	1.875	1.812	2.165	2.066	27/32	0.876	0.749	3 1/4

\*\* Hex Lag Screw



Office No.02, 1st Floor, Shreeji Plaza, CHS Tata Road  
No 02, Opera House, Charni Road Mumbai - 400004



+91-22-6659 5582 / 6659 5581 /  
4602 5379 (15 Lines)



info@adcoforge.com

GST NO : 27AAXCA2226N1Z4



www.adcoforge.com

# A-18

# TECHNICAL INFORMATION

## STEP BOLTS

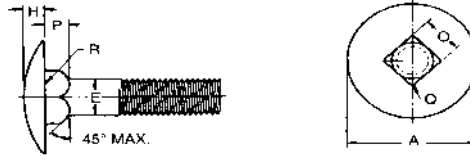

Nominal Size <sup>1</sup> or Basic Bolt Diameter	E		A		H		O		P		Q	R
	Body Diameter		Head Diameter		Head Height		Square Width		Square Depth		Corner Radius on Square	Fillet Radius
	Max	Min	Max	Min	Max	Min	Max	Min	Max	Min	Max	Max
No.10	0.199	0.182	0.656	0.625	0.114	0.094	0.199	0.185	0.125	0.094	0.031	0.031
1/4	0.260	0.237	0.844	0.813	0.145	0.125	0.260	0.245	0.156	0.125	0.031	0.031
5/16	0.324	0.298	1.031	1.000	0.176	0.156	0.324	0.307	0.187	0.156	0.031	0.031
3/8	0.388	0.360	1.249	1.188	0.208	0.188	0.388	0.368	0.219	0.188	0.047	0.031
7/16	0.452	0.421	1.406	1.375	0.239	0.219	0.452	0.431	0.250	0.219	0.047	0.031
1/2	0.515	0.483	1.594	1.563	0.270	0.250	0.515	0.492	0.281	0.250	0.047	0.031

<sup>1</sup> Where specifying nominal size in decimals, zeros preceding decimal and in the fourth decimal place shall be omitted.

## ELEVATOR BOLTS

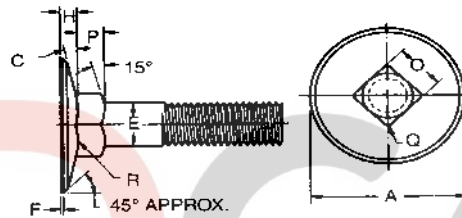

Nominal Size <sup>1</sup> or Basic Bolt Diameter	E		A			C	F	H		O		P		Q	R
	Body Diameter		Head Diameter			Head Angle	Flat on Min Dia. Head	Head Height		Square Width		Square Depth		Corner Radius On Square	Fillet Radius
	Max	Min	Max Edge Sharp	Min Edge Sharp	Min Edge Flat			Max	Min	Max	Min	Max	Min		
	Max	Min	Max	Min	Min	Ref	Max	Max	Min	Max	Min	Max	Min	Max	Max
No.10	0.199	0.182	0.790	0.750	0.740	9°	0.025	0.082	0.062	0.210	0.185	0.125	0.094	0.031	0.031
1/4	0.260	0.237	1.080	0.969	0.938	9°	0.035	0.098	0.078	0.280	0.245	0.219	0.188	0.031	0.031
5/16	0.324	0.298	1.227	1.188	1.157	9°	0.035	0.114	0.094	0.342	0.307	0.250	0.219	0.031	0.031
3/8	0.388	0.360	1.352	1.312	1.272	11°	0.040	0.145	0.125	0.405	0.368	0.250	0.219	0.047	0.031
7/16	0.452	0.421	1.477	1.438	1.397	13°	0.040	0.176	0.156	0.468	0.431	0.281	0.250	0.047	0.031
1/2	0.515	0.483	1.602	1.562	1.532	12°	0.040	0.176	0.156	0.530	0.492	0.281	0.250	0.047	0.031

<sup>1</sup> Where specifying nominal size in decimals, zeroes preceding decimal and in the fourth decimal place shall be omitted.

## NO. 3 HEAD PLOW BOLTS

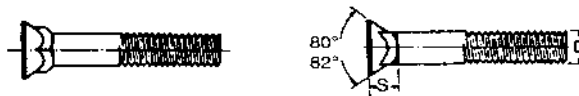

Nominal Diameter of Bolt	A			F	S		B	
	Diameter of Head			Feed Thickness	Depth of Square and Head		Width of Square	
	Max	Min Sharp	Abs. Min. With Flat	Max	Max	Min	Max	Min (Basic)
3/8	0.708	0.671	0.656	0.031	0.312	0.281	0.387	0.375
7/16	0.826	0.781	0.766	0.036	0.364	0.328	0.450	0.438
1/2	0.945	0.890	0.875	0.042	0.417	0.375	0.515	0.500
5/8	1.147	1.094	1.063	0.050	0.506	0.456	0.640	0.625



# TECHNICAL INFORMATION

## CARRIAGE BOLTS ASTM A307 Grade A

Carriage bolts with UNRC-2A threads can be furnished in two different styles: square-neck carriage bolts in diameters from 1/4" to 3/4", inclusive and short square-neck carriage bolts in diameters from 1/4" to 5/8" inclusive.

*Dimensional data for both styles are shown below.*

### MINIMUM THREAD LENGTH

The formula for determining thread length is, Bolts 6" and shorter, 2 diameters plus 1/4". Bolts over 6" 2 diameters plus 1/2". If bolts are too short to apply the formula, the thread will be extended as close to head as possible.

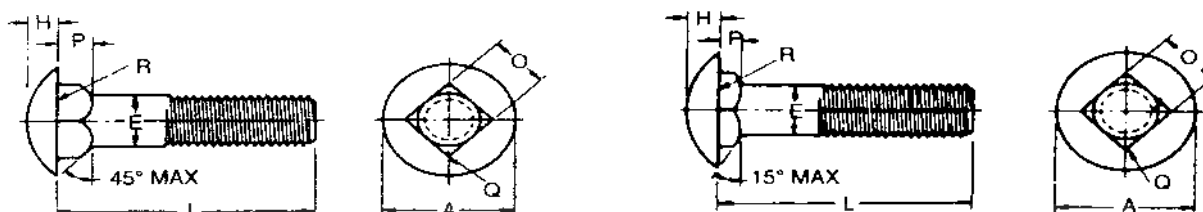

### Square-neck carriage bolt dimensions (in.) ANSI B18.5

Nominal Size or Basic Bolt Diameter	Body Diameter		Head Diameter		Head Height		Square Width		Square Depth		Corner Radius on Square	Fillet Radius	
	E		A		H		O		P		Q	R	
	Max	Min	Max	Min	Max	Min	Max	Min	Max	Min	Max	Max	
1/4	0.1900	0.199	0.182	0.469	0.438	0.144	0.094	0.199	0.185	0.125	0.094	0.031	0.031
1/4	0.2500	0.260	0.237	0.594	0.563	0.145	0.125	0.260	0.245	0.156	0.125	0.031	0.031
5/16	0.3125	0.324	0.298	0.719	0.688	0.176	0.156	0.324	0.307	0.187	0.156	0.031	0.031
3/8	0.3750	0.388	0.360	0.844	0.782	0.208	0.188	0.388	0.368	0.219	0.188	0.047	0.031
7/16	0.4375	0.452	0.421	0.969	0.907	0.239	0.219	0.452	0.431	0.250	0.219	0.047	0.031
1/2	0.5000	0.515	0.483	1.094	1.032	0.270	0.250	0.515	0.492	0.281	0.250	0.047	0.031
5/8	0.6250	0.642	0.605	1.344	1.219	0.344	0.313	0.642	0.616	0.344	0.313	0.078	0.062
3/4	0.7500	0.768	0.729	1.594	1.469	0.406	0.375	0.768	0.741	0.406	0.375	0.078	0.062

Full size body bolts are furnished unless user specifies undersize body bolts.

### Short Square-neck carriage bolt dimensions (in.) ANSI B18.5

Nominal Size or Basic Bolt Diameter	Body Diameter		Head Diameter		Head Height		Square Width		Square Depth		Corner Radius on Square	Fillet Radius	
	E		A		H		O		P		Q	R	
	Max	Min	Max	Min	Max	Min	Max	Min	Max	Min	Max	Max	
1/4	0.2500	0.260	0.213	0.594	0.563	0.145	0.125	0.260	0.245	0.124	0.093	0.031	0.031
5/16	0.3125	0.324	0.272	0.719	0.688	0.176	0.156	0.324	0.307	0.124	0.093	0.031	0.031
3/8	0.3750	0.388	0.329	0.844	0.782	0.208	0.188	0.388	0.368	0.156	0.125	0.047	0.031
7/16	0.4375	0.452	0.385	0.969	0.907	0.239	0.219	0.452	0.431	0.156	0.125	0.047	0.031
1/2	0.5000	0.515	0.444	1.094	1.032	0.270	0.250	0.515	0.492	0.156	0.125	0.047	0.031
5/8	0.6250	0.642	0.559	1.344	1.219	0.344	0.313	0.642	0.616	0.218	0.187	0.078	0.062

Undersize body bolts are furnished unless user specifies full-size body bolts.



**A-20**
**TECHNICAL INFORMATION**
**LENGTH TOLERANCES  
MACHINE SCREWS**

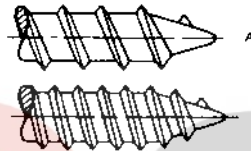

Nominal Screw Size	0 thru 12	1/4 thru 3/4
Nominal Screw Length	Tolerance on Length	
Up to 1/2", Incl.	-0.02	-0.03
Over 1/2" to 1", Incl.	-0.03	-0.03
Over 1" to 2", Incl.	-0.06	-0.06
Over 2"	-0.09	-0.09

**WOOD SCREWS**

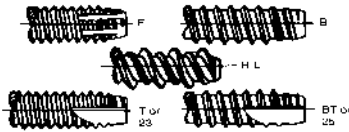
Nominal Screw Length	Tolerance on Length
Up to 5/8", Incl.	-0.03
Over 5/8" to 1 1/2", Incl.	-0.05
Over 1 1/2" to 2 3/4", Incl.	-0.06
Over 2 3/4" to 5", Incl.	-0.09

**TYPE A - AB**

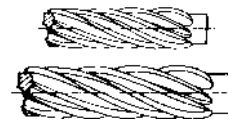
Nominal Screw Length	Tolerance on Length
Up to 1", Incl.	±0.03
Over 1"	±0.05

**TYPE B, F, H - L,  
25 and 23**

Nominal Screw Length	Tolerance on Length
Up to 3/4", Incl.	-0.03
Over 3/4" to 1 1/2", Incl.	-0.05

**TYPE U**

Nominal Screw Length	Tolerance on Length
Up to 3/8", Incl.	±0.02
Over 3/8"	±0.03



## TECHNICAL INFORMATION

A-21

### BINDING HEAD

### MACHINE SCREWS

(Specify undercut or not undercut)

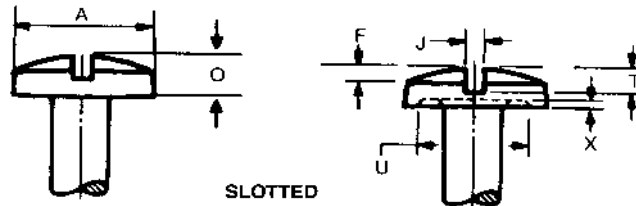

Basic Screw Diameter	A		O		F		J		T		U		X	
	Head Diameter		Total Head Weight		Head Oval Height		Slot Width		Slot Width		Undercut Diameter		Undercut Depth	
	Max	Min	Max	Min	Max	Min	Max	Min	Max	Min	Max	Min	Max	Min
0000	0.046	0.040	0.014	0.009	0.006	0.003	0.008	0.004	0.009	0.005	-	-	-	-
000	0.073	0.067	0.021	0.015	0.008	0.005	0.012	0.006	0.013	0.009	-	-	-	-
00	0.098	0.090	0.028	0.023	0.011	0.007	0.017	0.010	0.018	0.012	-	-	-	-
0	0.126	0.119	0.032	0.026	0.012	0.008	0.023	0.016	0.018	0.009	0.098	0.086	0.007	0.002
1	0.153	0.145	0.041	0.035	0.015	0.011	0.026	0.019	0.024	0.014	0.120	0.105	0.008	0.003
2	0.181	0.171	0.050	0.043	0.018	0.013	0.031	0.023	0.030	0.020	0.141	0.124	0.010	0.005
3	0.208	0.197	0.059	0.052	0.022	0.016	0.035	0.027	0.036	0.025	0.162	0.143	0.011	0.006
4	0.235	0.223	0.068	0.061	0.025	0.018	0.039	0.031	0.042	0.030	0.184	0.161	0.012	0.007
5	0.263	0.249	0.078	0.069	0.029	0.021	0.043	0.035	0.048	0.035	0.205	0.180	0.014	0.009
6	0.290	0.275	0.087	0.078	0.032	0.024	0.048	0.039	0.053	0.040	0.226	0.199	0.015	0.010
8	0.344	0.326	0.105	0.095	0.039	0.029	0.054	0.045	0.065	0.050	0.269	0.236	0.017	0.012
10	0.399	0.378	0.123	0.112	0.045	0.034	0.060	0.050	0.077	0.060	0.312	0.274	0.020	0.015
12	0.454	0.430	0.141	0.130	0.052	0.039	0.067	0.056	0.089	0.070	0.354	0.311	0.023	0.018
1/4	0.525	0.498	0.165	0.152	0.061	0.046	0.075	0.064	0.105	0.084	0.410	0.360	0.026	0.021
5/16	0.656	0.622	0.209	0.194	0.077	0.059	0.084	0.072	0.134	0.108	0.513	0.450	0.032	0.027
3/8	0.788	0.746	0.253	0.235	0.094	0.071	0.094	0.081	0.163	0.132	0.615	0.540	0.039	0.034

### HEX WASHER HEAD

### MACHINE SCREWS

### TAPPING SCREWS

### SELF DRILLING SCREWS

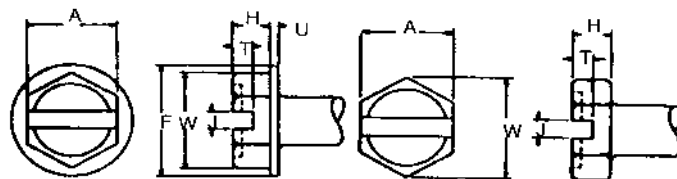

Nominal Size	A		W		H		F		U		I		T	
	Width Across Flats		Width Across Corners		Height of Head		Diameter of Washer		Thickness of Washer		Width of Slot		Depth of Slot	
	Max	Min	Max	Min	Max	Min	Max	Min	Max	Min	Max	Min	Max	Min
4	0.187	0.181	-	0.202	0.060	0.049	0.243	0.225	0.019	0.011	0.039	0.031	0.042	0.025
6	0.250	0.244	-	0.272	0.093	0.080	0.328	0.302	0.025	0.015	0.048	0.039	0.053	0.033
8	0.250	0.244	-	0.272	0.110	0.096	0.348	0.322	0.031	0.019	0.054	0.045	0.074	0.052
10	0.312	0.305	-	0.340	0.120	0.105	0.414	0.384	0.031	0.019	0.060	0.050	0.080	0.057
12	0.312	0.305	-	0.340	0.155	0.139	0.432	0.398	0.039	0.022	0.067	0.056	0.103	0.077
14	0.375	0.367	-	0.409	0.190	0.172	0.520	0.480	0.050	0.030	0.075	0.064	0.111	0.083
1/4	0.375	0.367	-	0.409	0.190	0.172	0.520	0.480	0.050	0.030	0.075	0.064	0.111	0.083
5/16	0.500	0.489	-	0.545	0.230	0.208	0.676	0.624	0.055	0.035	0.084	0.072	0.134	0.100



**A-22**
**TECHNICAL INFORMATION**
**FILLISTER HEAD  
MACHINE SCREWS**

Basic Screw Diameter	A		H		O		J		T	
	Head Diameter		Head Side Height		Total Head Height		Slot Width		Slot Depth	
	Max	Min	Max	Min	Max	Min	Max	Min	Max	Min
0000	0.038	0.032	0.019	0.011	0.025	0.015	0.008	0.004	0.012	0.006
000	0.059	0.053	0.029	0.021	0.035	0.027	0.012	0.006	0.017	0.011
00	0.082	0.072	0.037	0.028	0.047	0.039	0.017	0.010	0.022	0.015
0	0.096	0.083	0.043	0.038	0.055	0.047	0.023	0.016	0.025	0.015
1	0.118	0.104	0.053	0.045	0.066	0.058	0.026	0.019	0.031	0.020
2	0.140	0.124	0.062	0.053	0.083	0.066	0.031	0.023	0.037	0.025
3	0.161	0.145	0.070	0.061	0.095	0.077	0.035	0.027	0.043	0.030
4	0.183	0.166	0.079	0.069	0.107	0.088	0.039	0.031	0.048	0.035
5	0.205	0.187	0.088	0.078	0.120	0.100	0.043	0.035	0.054	0.040
6	0.226	0.208	0.096	0.086	0.132	0.111	0.048	0.039	0.060	0.045
8	0.270	0.250	0.113	0.102	0.156	0.133	0.054	0.045	0.071	0.054
10	0.313	0.292	0.130	0.118	0.180	0.156	0.060	0.050	0.083	0.064
12	0.357	0.334	0.148	0.134	0.205	0.178	0.067	0.056	0.094	0.074
1/4	0.414	0.389	0.170	0.155	0.237	0.207	0.075	0.064	0.109	0.087
5/16	0.518	0.490	0.211	0.194	0.295	0.262	0.084	0.072	0.137	0.110
3/8	0.622	0.590	0.253	0.233	0.355	0.315	0.094	0.081	0.164	0.133
7/16	0.625	0.589	0.265	0.242	0.368	0.321	0.094	0.081	0.170	0.135
1/2	0.750	0.710	0.297	0.273	0.412	0.362	0.106	0.091	0.190	0.151
9/16	0.812	0.768	0.336	0.308	0.466	0.410	0.118	0.102	0.214	0.172
5/8	0.875	0.827	0.375	0.345	0.521	0.461	0.133	0.116	0.240	0.193
3/4	1.000	0.945	0.441	0.406	0.612	0.542	0.149	0.131	0.281	0.226

Basic Screw Diameter	M		G		N	Driver Size
	Recess Diameter		Recess Depth		Recess Width	
	Max	Min	Max	Min	Min	
0	0.067	0.054	0.039	0.021	0.013	0
1	0.074	0.061	0.045	0.025	0.014	0
2	0.104	0.091	0.059	0.041	0.017	1
3	0.112	0.099	0.068	0.050	0.019	1
4	0.122	0.109	0.078	0.060	0.019	1
5	0.143	0.130	0.067	0.042	0.027	2
6	0.166	0.153	0.091	0.066	0.028	2
8	0.182	0.169	0.108	0.082	0.030	2
10	0.199	0.186	0.124	0.100	0.031	2
12	0.259	0.246	0.141	0.115	0.034	3
1/4	0.281	0.268	0.161	0.135	0.036	3
5/16	0.322	0.309	0.203	0.177	0.042	3
3/8	0.389	0.376	0.233	0.210	0.065	4
7/16	0.413	0.400	0.259	0.234	0.068	4
1/2	0.435	0.422	0.280	0.255	0.071	4
9/16	0.470	0.442	0.312	0.288	0.076	4
5/8	0.587	0.564	0.343	0.314	0.081	5
3/4	0.633	0.610	0.382	0.355	0.086	5

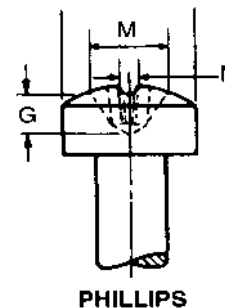
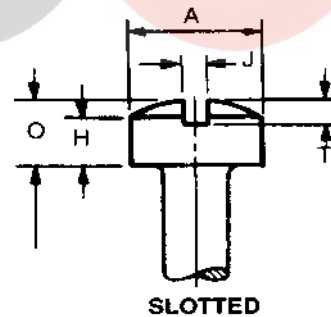



# TECHNICAL INFORMATION

A-23

## FLAT HEAD MACHINE SCREWS WOOD SCREWS TAPPING SCREWS

Basic Screw Diameter	A		H	J		T	
	Head Diameter		Head Height	Slot Width		Slot Depth	
	Max Edge Sharp	Min Edge Rounded or Flat		Ref	Max	Min	Max
0000	0.043	0.037	0.011	0.008	0.004	0.007	0.003
000	0.064	0.058	0.016	0.011	0.007	0.009	0.005
00	0.092	0.076	0.028	0.017	0.010	0.014	0.009
0	0.119	0.099	0.035	0.023	0.016	0.015	0.010
1	0.146	0.123	0.043	0.026	0.019	0.019	0.012
2	0.172	0.147	0.051	0.031	0.023	0.023	0.015
3	0.199	0.171	0.059	0.035	0.027	0.027	0.017
4	0.225	0.195	0.067	0.039	0.031	0.030	0.020
5	0.252	0.220	0.075	0.043	0.035	0.034	0.022
6	0.279	0.244	0.083	0.048	0.039	0.038	0.024
8	0.332	0.292	0.100	0.054	0.045	0.045	0.029
10	0.385	0.340	0.116	0.060	0.050	0.053	0.034
12	0.438	0.389	0.132	0.067	0.056	0.060	0.039
1/4	0.507	0.452	0.153	0.075	0.064	0.070	0.046
5/16	0.635	0.568	0.191	0.084	0.072	0.088	0.058
3/8	0.762	0.685	0.230	0.094	0.081	0.106	0.070
7/16	0.812	0.723	0.223	0.094	0.081	0.103	0.066
1/2	0.875	0.775	0.223	0.106	0.091	0.103	0.065
9/16	1.000	0.889	0.260	0.118	0.102	0.120	0.077
5/8	1.125	1.002	0.298	0.133	0.116	0.137	0.088
3/4	1.375	1.230	0.372	0.149	0.131	0.171	0.111

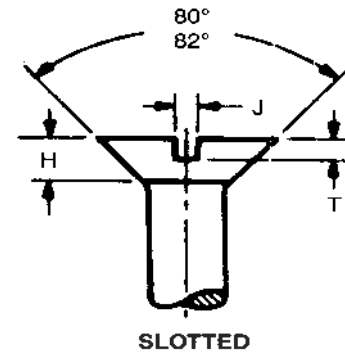

Nominal Size or Basic Screw Diameter	M		G		N	Driver Size	
	Recess Diameter		Recess Depth		Recess Width		
	Max	Min	Max	Min	Min		
0	0.0600	0.069	0.056	0.043	0.027	0.014	0
1	0.0730	0.077	0.064	0.051	0.035	0.015	0
2	0.0860	0.102	0.089	0.063	0.047	0.017	1
3	0.0990	0.107	0.094	0.068	0.052	0.018	1
4	0.1120	0.128	0.115	0.089	0.073	0.018	1
5	0.1250	0.154	0.141	0.086	0.063	0.027	2
6	0.1380	0.174	0.161	0.106	0.083	0.029	2
8	0.1640	0.189	0.176	0.121	0.098	0.030	2
10	0.1900	0.204	0.191	0.136	0.113	0.032	2
12	0.2160	0.268	0.255	0.156	0.133	0.035	3
1/4	0.2500	0.283	0.270	0.171	0.148	0.036	3
5/16	0.3125	0.365	0.352	0.216	0.194	0.061	4
3/8	0.3750	0.393	0.380	0.245	0.223	0.065	4
7/16	0.4375	0.409	0.396	0.261	0.239	0.068	4
1/2	0.5000	0.424	0.411	0.276	0.254	0.069	4
9/16	0.5625	0.454	0.431	0.300	0.278	0.073	4
5/8	0.6250	0.576	0.553	0.342	0.316	0.079	5
3/4	0.7500	0.640	0.617	0.406	0.380	0.087	5

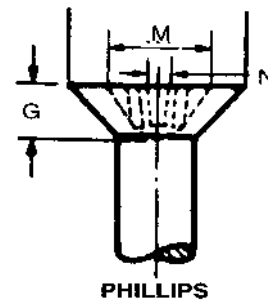

**A-24**
**TECHNICAL INFORMATION**
**FLAT HEAD UNDERCUT  
MACHINE SCREWS**

Nominal Size or Basic Screw Diameter	L These Lengths or Shorter are Undercut	A		H		J		T	
		Head Diameter		Head Height		Slot Width		Slot Depth	
		Max Edge Sharp	Min Edge Rounded or Flat	Max	Min	Max	Min	Max	Min
0	1/8	0.119	0.099	0.025	0.018	0.023	0.016	0.011	0.007
1	1/8	0.146	0.123	0.031	0.023	0.026	0.019	0.014	0.009
2	1/8	0.172	0.147	0.036	0.028	0.031	0.023	0.016	0.011
3	1/8	0.199	0.171	0.042	0.033	0.035	0.027	0.019	0.012
4	3/16	0.225	0.195	0.047	0.038	0.039	0.031	0.022	0.014
5	3/16	0.252	0.220	0.053	0.043	0.043	0.035	0.024	0.016
6	3/16	0.279	0.244	0.059	0.048	0.048	0.039	0.027	0.017
8	1/4	0.332	0.292	0.070	0.058	0.054	0.045	0.032	0.021
10	5/16	0.385	0.340	0.081	0.068	0.060	0.050	0.037	0.024
12	3/8	0.438	0.389	0.092	0.078	0.067	0.056	0.043	0.028
1/4	7/16	0.507	0.452	0.107	0.092	0.075	0.064	0.050	0.032
5/16	1/2	0.635	0.568	0.134	0.116	0.084	0.072	0.062	0.041
3/8	9/16	0.762	0.685	0.161	0.140	0.094	0.081	0.075	0.049
7/16	5/8	0.812	0.723	0.156	0.133	0.094	0.081	0.072	0.045
1/2	3/4	0.875	0.775	0.156	0.130	0.106	0.091	0.072	0.046

Nominal Size or Basic Screw Diameter	M		G		N	Driver Size
	Recess Diameter		Recess Depth		Recess Width	
	Max	Min	Max	Min	Min	
0	0.069	0.056	0.043	0.027	0.014	0
1	0.077	0.064	0.051	0.035	0.015	0
2	0.095	0.082	0.056	0.040	0.017	1
3	0.102	0.089	0.063	0.047	0.018	1
4	0.117	0.104	0.078	0.062	0.018	1
5	0.128	0.115	0.089	0.073	0.018	1
6	0.146	0.133	0.078	0.055	0.025	2
8	0.174	0.161	0.106	0.083	0.029	2
10	0.189	0.176	0.121	0.098	0.030	2
12	0.233	0.220	0.121	0.098	0.030	3
1/4	0.250	0.237	0.136	0.113	0.032	3
5/16	0.317	0.304	0.168	0.146	0.053	4
3/8	0.365	0.352	0.216	0.194	0.061	4
7/16	0.393	0.380	0.245	0.223	0.065	4
1/2	0.409	0.396	0.261	0.242	0.068	4

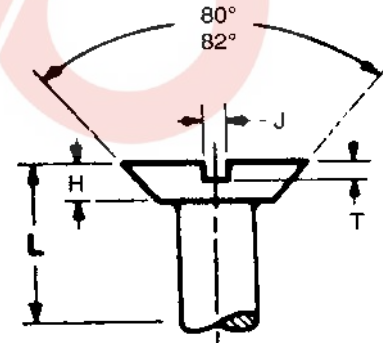
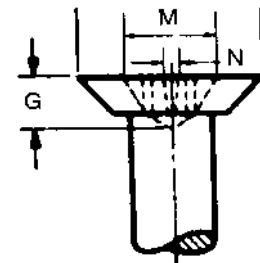
**SLOTTED**

**PHILLIPS**



# TECHNICAL INFORMATION

# A-25

## OVAL HEAD MACHINE SCREWS TAPPING SCREWS WOOD SCREWS

Basic Screw Diameter	A		H	O		J		T	
	Head Diameter		Head Side Height	Total Head Height		Slot Width		Slot Depth	
	Max Edge Sharp	Min Edge Rounded or Flat		Ref	Max	Min	Max	Min	Max
00	0.093	0.083	0.028	0.042	0.034	0.017	0.010	0.023	0.016
0	0.119	0.099	0.035	0.056	0.041	0.023	0.016	0.030	0.025
1	0.146	0.123	0.043	0.068	0.052	0.026	0.019	0.038	0.031
2	0.172	0.147	0.051	0.080	0.063	0.031	0.023	0.045	0.037
3	0.199	0.171	0.059	0.092	0.073	0.035	0.027	0.052	0.043
4	0.225	0.195	0.067	0.104	0.084	0.039	0.031	0.059	0.049
5	0.252	0.220	0.075	0.116	0.095	0.043	0.035	0.067	0.055
6	0.279	0.244	0.083	0.128	0.105	0.048	0.039	0.074	0.060
8	0.332	0.292	0.100	0.152	0.126	0.054	0.045	0.088	0.072
10	0.385	0.340	0.116	0.176	0.148	0.060	0.050	0.103	0.084
12	0.438	0.389	0.132	0.200	0.169	0.067	0.056	0.117	0.096
1/4	0.507	0.452	0.153	0.232	0.197	0.075	0.064	0.136	0.112
5/16	0.635	0.568	0.191	0.290	0.249	0.084	0.072	0.171	0.141
3/8	0.762	0.685	0.230	0.347	0.300	0.094	0.081	0.206	0.170
7/16	0.812	0.723	0.223	0.345	0.295	0.094	0.081	0.210	0.174
1/2	0.875	0.775	0.223	0.354	0.299	0.106	0.091	0.216	0.176
9/16	1.000	0.889	0.260	0.410	0.350	0.118	0.102	0.250	0.207
5/8	1.125	1.002	0.298	0.467	0.399	0.133	0.116	0.285	0.235
3/4	1.375	1.230	0.372	0.578	0.497	0.149	0.131	0.353	0.293

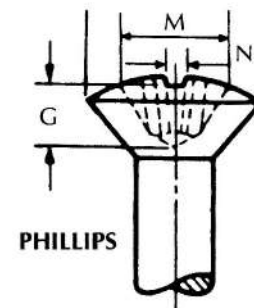
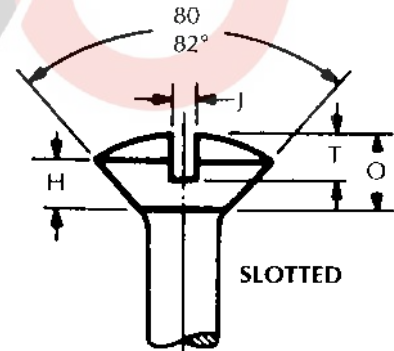
Basic Screw Diameter	M		G		N	Driver Size
	Recess Diameter		Recess Depth		Recess Width	
	Max	Min	Max	Min	Min	
0	0.074	0.061	0.045	0.027	0.014	0
1	0.077	0.064	0.048	0.030	0.015	0
2	0.112	0.099	0.069	0.052	0.018	1
3	0.124	0.111	0.081	0.064	0.019	1
4	0.136	0.123	0.094	0.077	0.019	1
5	0.158	0.145	0.085	0.061	0.028	2
6	0.178	0.165	0.105	0.080	0.030	2
8	0.192	0.179	0.119	0.095	0.031	2
10	0.209	0.196	0.137	0.113	0.033	2
12	0.270	0.257	0.152	0.128	0.038	3
1/4	0.290	0.277	0.173	0.148	0.040	3
5/16	0.381	0.368	0.226	0.202	0.064	4
3/8	0.400	0.387	0.245	0.221	0.066	4
7/16	0.410	0.397	0.257	0.233	0.068	4
1/2	0.422	0.409	0.269	0.245	0.070	4



# A-26

# TECHNICAL INFORMATION

## PAN HEAD

MACHINE SCREWS  
 TAPPING SCREWS  
 SELF DRILLING SCREWS

Nominal Size or Basic Screw Diameter	A		H		J		T	
	Head Diameter		Head Height (Slotted)		Slot Width		Slot Depth	
	Max	Min	Max	Min	Max	Min	Max	Min
0000	0.042	0.036	0.016	0.010	0.008	0.004	0.008	0.004
000	0.066	0.060	0.023	0.017	0.012	0.008	0.012	0.008
00	0.090	0.082	0.025	0.032	0.017	0.010	0.016	0.010
0	0.116	0.104	0.039	0.031	0.023	0.016	0.022	0.014
1	0.142	0.130	0.046	0.038	0.026	0.019	0.027	0.018
2	0.167	0.155	0.053	0.045	0.031	0.023	0.031	0.022
3	0.193	0.180	0.060	0.051	0.035	0.027	0.036	0.026
4	0.219	0.205	0.068	0.058	0.039	0.031	0.040	0.030
5	0.245	0.231	0.075	0.065	0.043	0.035	0.045	0.034
6	0.270	0.256	0.082	0.072	0.048	0.039	0.050	0.037
8	0.322	0.306	0.096	0.085	0.054	0.045	0.058	0.045
10	0.373	0.357	0.110	0.099	0.060	0.050	0.068	0.053
12	0.425	0.407	0.125	0.112	0.067	0.056	0.077	0.061
1/4	0.492	0.473	0.144	0.130	0.075	0.064	0.087	0.070
5/16	0.615	0.594	0.178	0.162	0.084	0.072	0.106	0.085
3/8	0.740	0.716	0.212	0.195	0.094	0.081	0.124	0.100
7/16	0.863	0.837	0.247	0.228	0.094	0.081	0.142	0.116
1/2	0.987	0.958	0.281	0.260	0.106	0.091	0.161	0.131
9/16	1.041	1.000	0.315	0.293	0.118	0.102	0.179	0.146
5/8	1.172	1.125	0.350	0.325	0.133	0.116	0.197	0.162
3/4	1.435	1.375	0.419	0.390	0.149	0.131	0.234	0.192

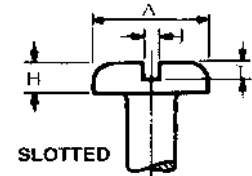

Nominal Size or Basic Screw Diameter	H		M		N		Driver Size	
	Head Height (Recessed)		Recess Diameter		Recess Depth			Recess Width
	Max	Min	Max	Min	Max	Min		Min
0	0.044	0.036	0.067	0.054	0.039	0.021	0.013	0
1	0.053	0.044	0.074	0.061	0.045	0.025	0.014	0
2	0.062	0.053	0.104	0.091	0.059	0.041	0.017	1
3	0.071	0.062	0.112	0.099	0.068	0.050	0.019	1
4	0.080	0.070	0.122	0.109	0.078	0.060	0.019	1
5	0.089	0.079	0.158	0.145	0.083	0.057	0.028	2
6	0.097	0.087	0.166	0.153	0.091	0.066	0.028	2
8	0.115	0.105	0.182	0.169	0.108	0.082	0.030	2
10	0.133	0.122	0.199	0.186	0.124	0.100	0.031	2
12	0.151	0.139	0.259	0.246	0.141	0.115	0.034	3
1/4	0.175	0.162	0.281	0.268	0.161	0.135	0.036	3
5/16	0.218	0.203	0.350	0.337	0.193	0.169	0.059	4
3/8	0.261	0.244	0.389	0.376	0.233	0.210	0.065	4
7/16	0.305	0.284	0.413	0.400	0.259	0.234	0.068	4
1/2	0.348	0.325	0.435	0.422	0.280	0.255	0.071	4
9/16	0.391	0.366	0.470	0.447	0.312	0.288	0.076	4
5/8	0.434	0.406	0.587	0.564	0.343	0.314	0.081	5
3/4	0.521	0.488	0.633	0.610	0.382	0.355	0.086	5

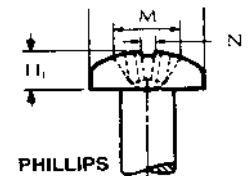

# TECHNICAL INFORMATION

# A-27

## ROUND HEAD MACHINE SCREWS WOOD SCREWS

Basic Screw Diameter	A		H		J		T	
	Head Diameter		Head Height		Slot Width		Slot Depth	
	Max	Min	Max	Min	Max	Min	Max	Min
0000	0.041	0.035	0.022	0.016	0.008	0.004	0.017	0.013
000	0.062	0.056	0.031	0.025	0.012	0.008	0.018	0.012
00	0.089	0.080	0.045	0.036	0.017	0.010	0.026	0.018
0	0.113	0.099	0.053	0.043	0.023	0.016	0.039	0.029
1	0.138	0.122	0.061	0.051	0.026	0.019	0.044	0.033
2	0.162	0.146	0.069	0.059	0.031	0.023	0.048	0.037
3	0.187	0.169	0.078	0.067	0.035	0.027	0.053	0.040
4	0.211	0.193	0.086	0.075	0.039	0.031	0.058	0.044
5	0.236	0.217	0.095	0.083	0.043	0.035	0.063	0.047
6	0.260	0.240	0.103	0.091	0.048	0.039	0.068	0.051
8	0.309	0.287	0.120	0.107	0.054	0.045	0.077	0.058
10	0.359	0.334	0.137	0.123	0.060	0.050	0.087	0.065
12	0.408	0.382	0.153	0.139	0.067	0.056	0.096	0.073
1/4	0.472	0.443	0.175	0.160	0.075	0.064	0.109	0.082
5/16	0.590	0.557	0.216	0.198	0.084	0.072	0.132	0.099
3/8	0.708	0.670	0.256	0.237	0.094	0.081	0.155	0.117
7/16	0.750	0.707	0.328	0.307	0.094	0.081	0.196	0.148
1/2	0.813	0.766	0.355	0.332	0.106	0.091	0.211	0.159
9/16	0.938	0.887	0.410	0.385	0.118	0.102	0.242	0.183
5/8	1.000	0.944	0.438	0.411	0.133	0.116	0.258	0.195
3/4	1.250	1.185	0.547	0.516	0.149	0.131	0.320	0.242

Basic Screw Diameter	M		G		N	Driver Size
	Recess Diameter		Recess Depth		Recess Width	
	Max	Min	Max	Min	Min	
0	0.073	0.060	0.042	0.022	0.014	0
1	0.082	0.069	0.052	0.033	0.015	0
2	0.100	0.087	0.053	0.034	0.017	1
3	0.109	0.096	0.062	0.042	0.018	1
4	0.118	0.105	0.072	0.053	0.019	1
5	0.154	0.141	0.074	0.046	0.027	2
6	0.162	0.149	0.084	0.056	0.027	2
8	0.178	0.165	0.101	0.075	0.030	2
10	0.195	0.182	0.119	0.093	0.031	2
12	0.249	0.236	0.125	0.099	0.032	3
1/4	0.268	0.255	0.147	0.121	0.034	3
5/16	0.308	0.295	0.187	0.161	0.040	3
3/8	0.387	0.374	0.228	0.202	0.064	4
7/16	0.402	0.389	0.241	0.216	0.066	4
1/2	0.416	0.403	0.256	0.231	0.068	4
9/16	0.459	0.436	0.292	0.265	0.075	4
5/8	0.554	0.531	0.318	0.277	0.077	5
3/4	0.654	0.631	0.418	0.379	0.088	5

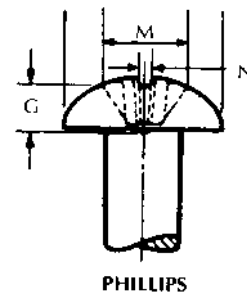
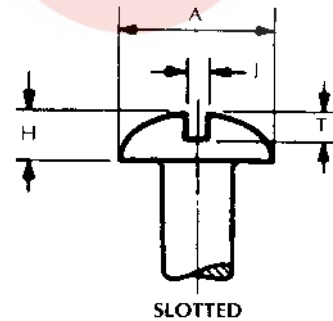

**A-28**
**TECHNICAL INFORMATION**
**TRUSS HEAD  
MACHINE SCREWS**

Basic Screw Diameter	A		H		J		T	
	Head Diameter		Head Height		Slot Width		Slot Depth	
	Max	Min	Max	Min	Max	Min	Max	Min
0000	0.049	0.043	0.014	0.010	0.009	0.005	0.009	0.005
000	0.077	0.071	0.022	0.018	0.013	0.009	0.013	0.009
00	0.106	0.098	0.030	0.024	0.017	0.010	0.018	0.012
0	0.131	0.119	0.037	0.029	0.023	0.016	0.022	0.014
1	0.164	0.149	0.045	0.037	0.026	0.019	0.027	0.018
2	0.194	0.180	0.053	0.044	0.031	0.023	0.031	0.022
3	0.226	0.211	0.061	0.051	0.035	0.027	0.036	0.026
4	0.257	0.241	0.069	0.059	0.039	0.031	0.040	0.030
5	0.289	0.272	0.078	0.066	0.043	0.035	0.045	0.034
6	0.321	0.303	0.086	0.074	0.048	0.039	0.050	0.037
8	0.384	0.364	0.102	0.088	0.054	0.045	0.058	0.045
10	0.448	0.425	0.118	0.103	0.060	0.050	0.068	0.053
12	0.511	0.487	0.134	0.118	0.067	0.056	0.077	0.061
1/4	0.573	0.546	0.150	0.133	0.075	0.064	0.087	0.070
5/16	0.698	0.666	0.183	0.162	0.084	0.072	0.106	0.085
3/8	0.823	0.787	0.215	0.191	0.094	0.081	0.124	0.100
7/16	0.948	0.907	0.248	0.221	0.094	0.081	0.142	0.116
1/2	1.073	1.028	0.280	0.250	0.106	0.091	0.161	0.131
9/16	1.198	1.149	0.312	0.279	0.118	0.102	0.179	0.146
5/8	1.323	1.269	0.345	0.309	0.133	0.116	0.196	0.162
3/4	1.573	1.511	0.410	0.368	0.149	0.131	0.234	0.182

Basic Screw Diameter	M		G		N	Driver Size
	Recess Diameter		Recess Depth		Recess Width	
	Max	Min	Max	Min	Min	
0	0.063	0.050	0.037	0.019	0.013	0
1	0.071	0.058	0.045	0.027	0.014	0
2	0.104	0.091	0.059	0.041	0.018	1
3	0.110	0.097	0.066	0.049	0.018	1
4	0.112	0.099	0.069	0.051	0.018	1
5	0.128	0.115	0.085	0.067	0.019	1
6	0.158	0.145	0.084	0.059	0.027	2
8	0.173	0.160	0.099	0.074	0.029	2
10	0.188	0.175	0.115	0.090	0.030	2
12	0.248	0.235	0.128	0.103	0.032	3
1/4	0.263	0.250	0.143	0.118	0.033	3
5/16	0.352	0.339	0.193	0.168	0.059	4
3/8	0.383	0.370	0.226	0.202	0.063	4
7/16	0.414	0.401	0.257	0.232	0.068	4
1/2	0.444	0.431	0.288	0.263	0.072	4
9/16	0.451	0.428	0.302	0.278	0.074	4
5/8	0.559	0.536	0.322	0.289	0.077	5
3/4	0.620	0.597	0.384	0.352	0.085	5

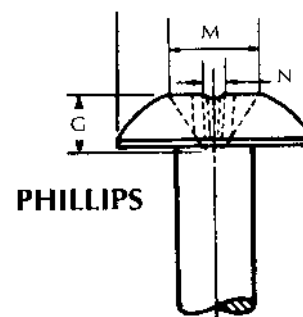
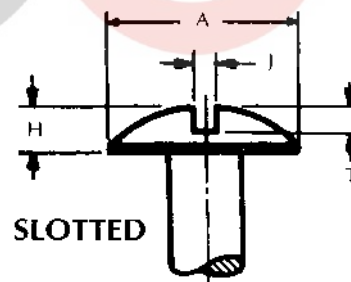

# TECHNICAL INFORMATION

A-29

## THUMB SCREWS

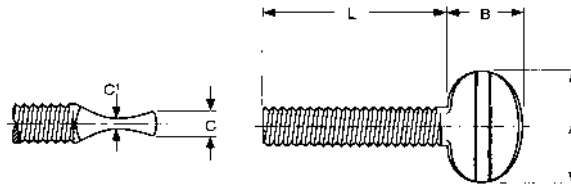

### PLAIN PATTERN – TYPE P

Nominal Size or Basic Screw Diameter	Threads Per Inch	A		B		C		C <sup>1</sup>		L	
		Head Width		Head Height		Head Thickness		Head Thickness		Practical Screw Lengths	
		Max	Min	Max	Min	Max	Min	Max	Min	Max	Min
6	32	0.45	0.43	0.28	0.26	0.08	0.06	0.03	0.02	1.00	0.25
8	32	0.51	0.49	0.32	0.30	0.09	0.07	0.04	0.02	1.00	0.38
10	24 & 32	0.58	0.54	0.39	0.36	0.10	0.08	0.05	0.03	2.00	0.38
12	24	0.71	0.67	0.45	0.43	0.11	0.09	0.05	0.03	2.00	0.38
1/4	20	0.83	0.80	0.52	0.48	0.16	0.14	0.06	0.03	2.50	0.50
5/16	18	0.96	0.91	0.64	0.60	0.17	0.14	0.09	0.06	3.00	0.50
3/8	16	1.09	1.03	0.71	0.67	0.22	0.18	0.11	0.08	3.00	0.75
7/16	14	1.40	1.35	0.96	0.91	0.27	0.24	0.14	0.11	4.00	1.00
1/2	13	1.54	1.46	1.09	1.03	0.33	0.29	0.15	0.11	4.00	1.00

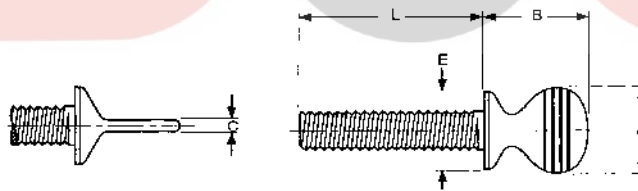

### SHOULDER PATTERN – TYPE S

Nominal Size or Basic Screw Diameter	Threads Per Inch	A		B		C		E		L	
		Head Width		Head Height		Head Thickness		Shoulder Diameter		Practical Screw Lengths	
		Max	Min	Max	Min	Max	Min	Max	Min	Max	Min
6	32	0.31	0.29	0.33	0.31	0.05	0.04	0.25	0.23	0.75	0.25
8	32	0.36	0.34	0.38	0.36	0.06	0.05	0.31	0.29	0.75	0.38
10	24 & 32	0.42	0.40	0.48	0.46	0.06	0.05	0.35	0.32	1.00	0.38
12	24	0.48	0.46	0.54	0.52	0.06	0.05	0.40	0.38	1.00	0.38
1/4	20	0.55	0.52	0.64	0.61	0.07	0.05	0.47	0.44	1.50	0.50
5/16	18	0.70	0.67	0.78	0.75	0.09	0.07	0.59	0.56	1.50	0.50
3/8	16	0.83	0.80	0.95	0.92	0.11	0.09	0.76	0.71	2.00	0.75

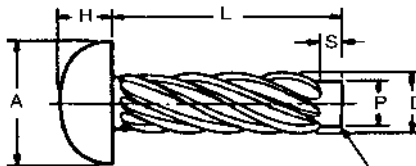

**DRIVE SCREWS  
 TYPE U  
 ROUND HEAD**

Nominal Screw Size	Number of Thread Starts	D		A		H		P		Recommended Hole Size	
		Outside Diameter		Head Diameter		Head Height		Pilot Diameter		Drill Size No.	Hole Diameter
		Max	Min	Max	Min	Max	Min	Max	Min		
00	6	0.060	0.057	0.099	0.090	0.034	0.026	0.049	0.046	55	0.052
0	6	0.075	0.072	0.127	0.118	0.049	0.041	0.063	0.060	51	0.067
2	8	0.100	0.097	0.162	0.146	0.069	0.059	0.083	0.080	44	0.086
4	7	0.116	0.112	0.211	0.193	0.086	0.075	0.096	0.092	37	0.104
6	7	0.140	0.136	0.260	0.240	0.103	0.091	0.116	0.112	31	0.120
7	8	0.154	0.150	0.285	0.264	0.111	0.099	0.126	0.122	29	0.136
8	8	0.167	0.162	0.309	0.287	0.120	0.107	0.136	0.132	27	0.144
10	8	0.182	0.177	0.359	0.334	0.137	0.123	0.150	0.146	20	0.161
12	8	0.212	0.206	0.408	0.382	0.153	0.139	0.177	0.173	11	0.191
14	9	0.236	0.242	0.457	0.429	0.170	0.155	0.202	0.198	2	0.221
<b>L</b>	<b>Nominal Screw Length</b>		1/8	3/16	1/4	5/16	3/8	1/2	5/8	3/4	1" and
<b>S</b>	<b>Pilot Length</b>		0.047	0.047	0.047	0.047	0.062	0.062	0.078	0.078	0.125

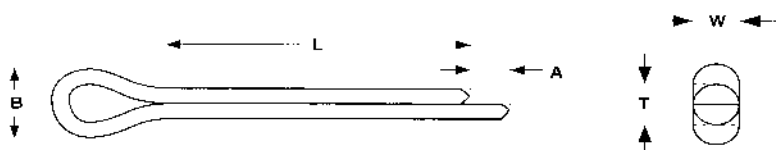
**COTTER PINS**

Nominal Size	Basic Pin Diameter	T		W		B	A	Gage Hole Diameter (±0.001)
		Total Shank Diameter		Wire Width		Head Diameter	Extended Prong Length	
		Max	Min	Max	Min	Min	Min	
1/16	0.062	0.060	0.056	0.060	0.044	0.12	0.03	0.078
3/32	0.094	0.090	0.086	0.090	0.069	0.19	0.04	0.109
1/8	0.125	0.120	0.116	0.120	0.093	0.25	0.06	0.141
5/32	0.156	0.150	0.146	0.150	0.116	0.31	0.07	0.172
3/16	0.188	0.176	0.172	0.176	0.137	0.38	0.09	0.203
7/32	0.219	0.207	0.202	0.207	0.161	0.44	0.10	0.234
1/4	0.250	0.225	0.220	0.225	0.176	0.50	0.11	0.266
5/16	0.312	0.280	0.275	0.280	0.220	0.62	0.14	0.312
3/8	0.375	0.335	0.329	0.335	0.263	0.75	0.16	0.375
1/2	0.500	0.473	0.467	0.473	0.373	1.00	0.23	0.500





# TECHNICAL INFORMATION

A-31

## HEX SOCKET HEAD CAP SCREWS 1960 Series

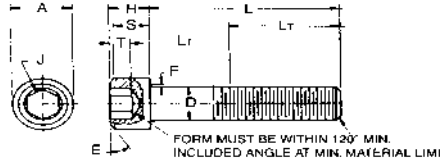

Nominal Size or Basic Screw Diameter	D		A		H		S	J	T	F		L <sub>T</sub>	
	Body Diameter		Head Diameter		Head Height		Head Side Height	Hexagon Socket Size	Key Engagement	Fillet Extension Above D		Thread Length	
	Max	Min	Max	Min	Max	Min	Min	Nom	Min	Max	Min	Min	
0	0.0600	0.0600	0.0568	0.096	0.091	0.060	0.057	0.054	0.050	0.025	0.007	0.003	0.50
1	0.0730	0.0730	0.0695	0.118	0.112	0.073	0.070	0.066	1/16 0.062	0.031	0.007	0.003	0.62
2	0.0860	0.0860	0.0822	0.140	0.134	0.086	0.083	0.077	5/64 0.078	0.038	0.008	0.004	0.62
3	0.0990	0.0990	0.0949	0.161	0.154	0.099	0.095	0.089	5/64 0.078	0.044	0.008	0.004	0.62
4	0.1120	0.1120	0.1075	0.183	0.176	0.112	0.108	0.101	3/32 0.094	0.051	0.009	0.005	0.75
5	0.1250	0.1250	0.1202	0.205	0.198	0.125	0.121	0.112	3/32 0.094	0.057	0.010	0.006	0.75
6	0.1380	0.1380	0.1329	0.226	0.218	0.138	0.134	0.124	7/64 0.109	0.064	0.010	0.006	0.75
8	0.1640	0.1640	0.1585	0.270	0.262	0.164	0.159	0.148	9/64 0.141	0.077	0.012	0.007	0.88
10	0.1900	0.1900	0.1840	0.312	0.303	0.190	0.185	0.171	5/32 0.156	0.090	0.014	0.009	0.88
1/4	0.2500	0.2500	0.2435	0.375	0.365	0.250	0.244	0.225	3/16 0.188	0.120	0.014	0.009	1.00
5/16	0.3125	0.3125	0.3053	0.469	0.457	0.312	0.306	0.281	1/4 0.250	0.151	0.017	0.012	1.12
3/8	0.3750	0.3750	0.3678	0.562	0.550	0.375	0.368	0.337	5/16 0.312	0.182	0.020	0.015	1.25
7/16	0.4375	0.4375	0.4294	0.656	0.642	0.438	0.430	0.394	3/8 0.375	0.213	0.023	0.018	1.38
1/2	0.5000	0.5000	0.4919	0.750	0.735	0.500	0.492	0.450	3/8 0.375	0.245	0.026	0.020	1.50
5/8	0.6250	0.6250	0.6163	0.938	0.921	0.625	0.616	0.562	1/2 0.500	0.307	0.032	0.024	1.75
3/4	0.7500	0.7500	0.7406	1.125	1.107	0.750	0.740	0.675	5/8 0.625	0.370	0.039	0.030	2.00
7/8	0.8750	0.8750	0.8647	1.312	1.293	0.875	0.864	0.787	3/4 0.750	0.432	0.044	0.034	2.25
1	1.0000	1.0000	0.9886	1.500	1.479	1.000	0.988	0.900	3/4 0.750	0.495	0.050	0.040	2.50
1 1/4	1.2500	1.2500	1.2336	1.875	1.852	1.250	1.236	1.125	7/8 0.875	0.620	0.060	0.050	3.12
1 1/2	1.5000	1.5000	1.4818	2.250	2.224	1.500	1.485	1.350	1 1.000	0.745	0.070	0.060	3.75

## HEX SOCKET BUTTON HEAD SCREWS

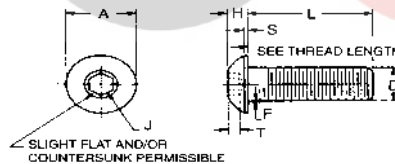

Nominal Size or Basic Screw Diameter	D		A		H		S	J	T	F		L
	Head Diameter		Head Diameter		Head Height		Head Side Height	Hexagon Socket Size	Key Engagement	Fillet Extension Above D		Maximum Standard Length
	Max	Min	Max	Min	Max	Min	Ref	Nom	Min	Max	Min	Nom
2	0.0860	0.164	0.154	0.046	0.038	0.010	0.010	0.050	0.028	0.010	0.005	1/2
3	0.0990	0.188	0.176	0.052	0.044	0.010	0.010	1/16 0.062	0.035	0.010	0.005	1/2
4	0.1120	0.213	0.201	0.059	0.051	0.015	0.015	1/16 0.062	0.035	0.010	0.005	1/2
5	0.1250	0.238	0.226	0.066	0.058	0.015	0.015	5/64 0.078	0.044	0.010	0.005	1/2
6	0.1380	0.262	0.250	0.073	0.063	0.015	0.015	5/64 0.078	0.044	0.010	0.005	5/8
8	0.1640	0.312	0.298	0.087	0.077	0.015	0.015	3/32 0.094	0.052	0.015	0.010	3/4
10	0.1900	0.361	0.347	0.101	0.091	0.020	0.020	1/8 0.125	0.070	0.015	0.010	1
1/4	0.2500	0.437	0.419	0.132	0.122	0.031	0.031	5/32 0.156	0.087	0.020	0.015	1
5/16	0.3125	0.547	0.527	0.166	0.152	0.031	0.031	3/16 0.188	0.105	0.020	0.015	1
3/8	0.3750	0.656	0.636	0.199	0.185	0.031	0.031	7/32 0.219	0.122	0.020	0.015	1 1/4
1/2	0.5000	0.875	0.851	0.265	0.245	0.046	0.046	5/16 0.312	0.175	0.030	0.020	2
5/8	0.6250	1.000	0.970	0.331	0.311	0.062	0.062	3/8 0.375	0.210	0.030	0.020	2

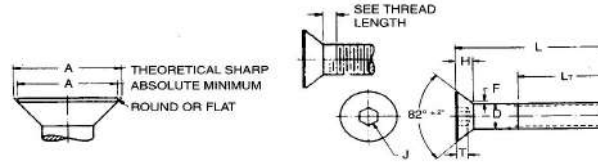

**A-32**
**TECHNICAL INFORMATION**
**HEX SOCKET  
FLAT HEAD SCREWS**

Nominal Size or Basic Screw Diameter	D		A		H		J		T	F	L <sub>T</sub>	
	Body Diameter		Head Diameter		Head Height		Hexagon Socket Size		Key Engagement	Fillet Extension Above D Max	Basic Thread Length	
	Max	Min	Theoretical Sharp Max	Abs. Min	Reference	Flushness Tolerance	Nominal	Max	Max	Min		
4	0.1120	0.1120	0.1075	0.255	0.218	0.083	0.011	1/16	0.062	0.055	0.012	0.750
5	0.1250	0.1250	0.1202	0.281	0.240	0.090	0.012	5/64	0.078	0.061	0.014	0.750
6	0.1380	0.1380	0.1329	0.307	0.263	0.097	0.013	5/64	0.078	0.066	0.015	0.750
8	0.1640	0.1640	0.1585	0.359	0.311	0.112	0.014	3/32	0.094	0.076	0.015	0.875
10	0.1900	0.1900	0.1840	0.411	0.359	0.127	0.015	1/8	0.125	0.087	0.015	0.875
1/4	0.2500	0.2500	0.2435	0.531	0.480	0.161	0.016	5/32	0.156	0.111	0.015	1.000
5/16	0.3125	0.3125	0.3053	0.656	0.600	0.198	0.017	3/16	0.188	0.135	0.015	1.125
3/8	0.3750	0.3750	0.3678	0.781	0.720	0.234	0.018	7/32	0.219	0.159	0.015	1.250
7/16	0.4375	0.4375	0.4294	0.844	0.781	0.234	0.018	1/4	0.250	0.159	0.015	1.375
1/2	0.5000	0.5000	0.4919	0.938	0.872	0.251	0.018	5/16	0.312	0.172	0.015	1.500
5/8	0.6250	0.6250	0.6163	1.188	1.112	0.324	0.022	3/8	0.375	0.220	0.015	1.750
3/4	0.7500	0.7500	0.7406	1.438	1.355	0.396	0.024	1/2	0.500	0.220	0.015	2.000

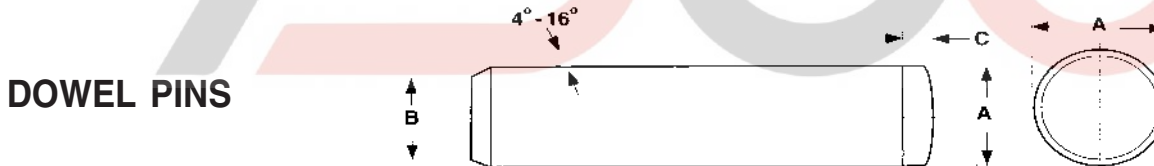
**DOWEL PINS**

Nominal Size	A				B	C	Shear Strength
	Standard Pin (0.002 over basic size)		Standard Pin (0.001 over basic size)		Point Diameter	Top Radius	Double Shear (Lbs.)
	Max	Min	Max	Min	Max		
1/8	0.1253	0.1251	0.1261	0.1259	0.119	3/64	3,600
3/16	0.1878	0.1876	0.1886	0.1884	0.176	3/64	8,000
1/4	0.2503	0.2501	0.2511	0.2509	0.239	1/16	14,400
5/16	0.3128	0.3126	0.3136	0.3134	0.301	1/16	22,400
3/8	0.3753	0.3751	0.3761	0.3759	0.364	5/64	32,400
7/16	0.4378	0.4376	0.4386	0.4384	0.4205	3/32	44,000
1/2	0.5003	0.5001	0.5011	0.5009	0.483	7/64	57,400
5/8	0.6253	0.6251	0.6261	0.6259	0.608	1/8	89,800
3/4	0.7503	0.7501	0.7511	0.7509	0.728	1/8	129,200
7/8	0.8753	0.8751	0.8761	0.8759	0.853	1/8	176,000
1	1.0003	1.0001	1.0001	1.0009	0.978	1/8	230,000



# TECHNICAL INFORMATION

A-33

## HEX SOCKET SHOULDER SCREWS

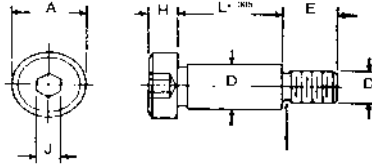

Nominal Size or Basic Shoulder Diameter	D		A		H		D		E	I	J			
	Shoulder Diameter		Head Diameter		Head Height		Nominal Thread Size or Basic Thread Diameter	Threads Per Inch	Thread Length	Thread Neck Width	Hexagon Socket Size			
	Max	Min	Max	Min	Max	Min			Basic	Max	Nom			
1/4	0.250	0.2480	0.2460	0.375	0.357	0.188	0.177	10	0.1900	24	0.375	0.062	1/8	0.125
5/16	0.312	0.3105	0.3085	0.438	0.419	0.219	0.209	1/4	0.2500	20	0.438	0.075	5/32	0.156
3/8	0.375	0.3730	0.3710	0.562	0.543	0.250	0.240	5/16	0.3125	18	0.500	0.083	3/16	0.188
1/2	0.500	0.4980	0.4960	0.750	0.729	0.312	0.302	3/8	0.3750	16	0.625	0.093	1/4	0.250
5/8	0.625	0.6230	0.6210	0.875	0.853	0.375	0.365	1/2	0.5000	13	0.750	0.115	5/16	0.312
3/4	0.750	0.7480	0.7460	1.000	0.977	0.500	0.490	5/8	0.6250	11	0.875	0.136	3/8	0.375
1	1.000	0.9980	0.9960	1.312	1.287	0.625	0.610	3/4	0.7500	10	1.000	0.150	1/2	0.500

## HEX SOCKET SET SCREWS

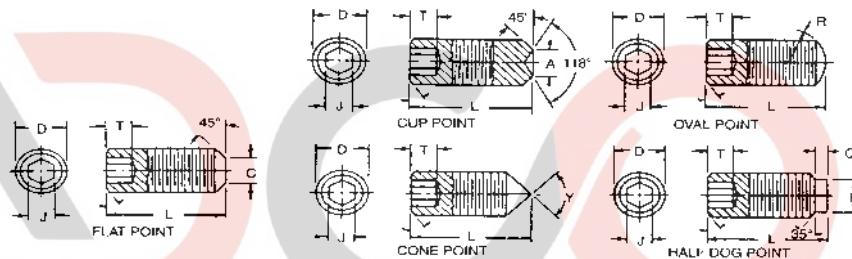

Nominal Diameter	D		A		R	Y	P		Q	J	T	Shorest Length to which Column T Applies
	Cup and Flat Point Diameter		Oval Point Radius	Cone Point Angle 90±2 For These Lengths and Over	Half Dog Point Diameter		Length Nom.	Socket Width Across Flats	Key Engagement			
	Max	Min			Max	Min				Nom	Min	
0	0.033	0.027	0.045	5/64	0.040	0.037	0.015	0.028	0.050	7/64		
1	0.040	0.033	0.055	3/32	0.049	0.045	0.019	0.035	0.060	1/8		
2	0.047	0.039	0.064	7/64	0.057	0.053	0.022	0.035	0.060	1/8		
3	0.054	0.045	0.074	1/8	0.066	0.062	0.025	0.050	0.070	9/64		
4	0.061	0.051	0.084	5/32	0.075	0.070	0.028	0.050	0.070	9/64		
5	0.067	0.057	0.094	3/16	0.083	0.078	0.030	1/16	0.080	3/16		
6	0.074	0.064	0.104	3/16	0.092	0.087	0.035	1/16	0.080	11/64		
8	0.087	0.076	0.123	1/4	0.109	0.103	0.040	5/64	0.090	3/16		
10	0.102	0.088	0.142	1/4	0.127	0.120	0.045	3/32	0.100	3/16		
1/4	0.132	0.118	0.188	5/16	5/32	0.149	1/16	1/8	0.125	1/4		
5/16	0.172	0.156	0.234	3/8	13/64	0.195	5/64	5/32	0.156	5/16		
3/8	0.212	0.194	0.281	7/16	1/4	0.241	3/32	3/16	0.188	3/8		
7/16	0.252	0.232	0.328	1/2	19/64	0.287	7/64	7/32	0.219	7/16		
1/2	0.291	0.270	0.375	9/16	11/32	0.334	1/8	1/4	0.250	1/2		
5/8	0.371	0.347	0.469	3/4	15/32	0.456	5/32	5/16	0.312	5/8		
3/4	0.450	0.425	0.562	7/8	9/16	0.549	3/16	3/8	0.375	3/4		
7/8	0.530	0.502	0.656	1	21/32	0.642	7/32	1/2	0.500	7/8		
1	0.609	0.579	0.750	1 1/8	3/4	0.734	1/4	9/16	0.562	1		



**METRIC THREAD AND DIN# INFORMATION**

	Standard Thread	Fine Thread	Extra Fine Thread
Size	Pitch	Pitch	Pitch
2mm	0.40	-	-
3mm	0.50	-	-
4mm	0.70	-	-
5mm	0.80	-	-
6mm	1.00	-	-
7mm	1.00	-	-
8mm	1.25	1.00	-
10mm	1.50	1.25	1.00
12mm	1.75	1.50	-
14mm	2.00	1.50	-
16mm	2.00	1.50	-
18mm	2.50	1.50	-
20mm	2.50	2.00	1.50
22mm	2.50	1.50	-
24mm	3.00	2.00	-
27mm	3.00	-	-
30mm	3.50	-	-
33mm	3.50	-	-
36mm	4.00	-	-

Din#	Description	
931	Coarse Thread Cap Screws	(Partially Threaded)
933	Coarse Thread Cap Screws	(Fully Threaded)
960	Fine Thread Cap Screws	(Partially Threaded)
961	Fine Thread Cap Screws	(Fully Threaded)
84	Cheese (Fillister) Machine Screws	(Slotted)
85	Pan Head Machine Screws	(Slotted)
963	Flat Head Machine Screws	(Slotted)
964	Oval Head Machine Screws	(Slotted)
966	Oval Head Machine Screws	(Phillips)
7985	Fillister Head Machine Screws	(Phillips)
125	Flat Washers	
127	Split Lock Washers	
6797	Tooth Lock Washers	
936	Jam Nuts	
934	Finished Hex Nuts	
985	Nylon Stop Nuts	
912	Socket Cap Screw	
439	Hex Jam Nut	
916	Socket Set Screw	



# TECHNICAL INFORMATION

# A-35

## METRIC CONVERSION GUIDE

### CONVERSION OF METRIC UNITS OF MEASUREMENTS INTO CUSTOMARY EQUIVALENTS

To convert from	To	Multiply by
Millimeters (mm)	Inches (in.)	$3.937 \times 10^{-2}$
Meters (m)	Inches (in.)	$3.937 \times 10$
Square Millimeters (mm <sup>2</sup> )	Square Inches (in. <sup>2</sup> )	$1.55 \times 10^{-3}$
Square Meters (m <sup>2</sup> )	Square Inches (in. <sup>2</sup> )	$1.55 \times 10^3$
Cubic Millimeters (mm <sup>3</sup> )	Cubic Inches (in. <sup>3</sup> )	$6.10234 \times 10^{-5}$
Cubic Meters (m <sup>3</sup> )	Cubic Inches (in. <sup>3</sup> )	$6.10234 \times 10^4$
Grams (g)	Ounces (avdp) (oz)	$3.5274 \times 10^{-2}$
Kilograms (kg)	Pounds (avdp) (lb)	2.20462
Newtons (N)	Pound Force (lbf)	$2.248 \times 10^{-1}$
Kilogram Force Per Square Millimeter (kgf/mm <sup>2</sup> )	Pounds Per Square Inch (psi)	$1.4223 \times 10^3$
Newton Per Square Millimeter (N/mm <sup>2</sup> )	Pounds Per Square Inch (psi)	$1.45038 \times 10^2$
Newton Per Square Meter (N/m <sup>2</sup> )	Pounds Per Square Inch (psi)	$1.45038 \times 10^{-4}$
Newton-Meter (N.m)	Ounce-Inch (oz-in.)	$1.41612 \times 10^2$
Newton-Meter (N.m)	Pound-Inch (lb-in.)	8.85073
Newton-Meter (N.m)	Pound-Foot (lb-ft)	$7.3756 \times 10^{-1}$
Degree Fahrenheit	Degree Celsius	$t_c = (t_f - 32)/1.8$
Kelvin (K)	Degree Celsius	$t_c = t_k - 273.15$

### CONVERSION OF CUSTOMARY UNITS OF MEASURE INTO METRIC EQUIVALENTS

Inches (in.)	Millimeters (mm)	$2.54 \times 10$
Inches (in.)	Meters (m)	$2.54 \times 10^{-2}$
Square Inches (in. <sup>2</sup> )	Square Millimeters (mm <sup>2</sup> )	$6.4516 \times 10^2$
Square Inches (in. <sup>2</sup> )	Square Meters (m <sup>2</sup> )	$6.4516 \times 10^{-4}$
Cubic Inches (in. <sup>3</sup> )	Cubic Millimeters (mm <sup>3</sup> )	$1.638706 \times 10^4$
Cubic Inches (in. <sup>3</sup> )	Cubic Meters (m <sup>3</sup> )	$1.638706 \times 10^{-5}$
Ounces (avdp) (oz)	Kilograms (kg)	$2.83495 \times 10^{-2}$
Pounds (avdp) (lb)	Kilograms (kg)	$4.53592 \times 10^{-1}$
Pound Force (lbf)	Newtons (N)	4.448
Pounds Per Square Inch (psi)	Kilograms Force Per Square Millimeter (kgf/mm <sup>2</sup> )	$7.0307 \times 10^{-4}$
Pounds Per Square Inch (psi)	Newton Per Square Meter (N/m <sup>2</sup> )	$6.894757 \times 10^3$
Pounds Per Square Inch (psi)	Mega Newton Per Square Meter (MN/m <sup>2</sup> )	$6.894757 \times 10^{-3}$
Ounce-Inch (oz-in.)	Newton-Meter (N.m)	$7.061552 \times 10^{-3}$
Pound-Inch (lb-in.)	Newton-Meter (N.m)	$1.129848 \times 10^{-1}$
Pound-Foot (lb-ft)	Newton-Meter (N.m)	1.355818
Degree Celsius	Kelvin (K)	$t_k = t_c + 273.15$
Degree Fahrenheit	Kelvin (K)	$t_k = (t_f + 459.67)/1.8$
Degree Rankine	Kelvin (K)	$t_k = t_r/1.8$

### ISO METRIC AND UNIFIED SCREW THREAD DESIGNATIONS

ISO metric screw threads are designated by basic diameter and thread pitch. As an example, M8 × 1 is a standard ISO Metric screw thread having a basic diameter of 8 millimeters and a thread pitch of 1 millimeter. To convert on ISO Metric screw thread designation to a Unified (American) designation divide the basic diameter by 25.4 and multiply the reciprocal of the pitch by 25.4 to determine nominal size in inches and threads per inch. By so doing, M8 × 1 becomes 0.315-25.4 UNS.

Unified screw threads are designated by nominal size and number of threads per inch. As an example, 3/4-10 UNC is a standard Unified screw thread having a nominal size of 3/4 inches and 10 threads per inch. To convert a Unified screw thread designation to an ISO Metric screw thread designation multiply nominal size by 25.4 and multiply the reciprocal of threads per inch by 25.4 to determine basic diameter in millimeters and pitch in millimeters. By so doing, 3/4-10 UNC converted to ISO Metric become M19.05 × 2.54.



# A-36

# TECHNICAL INFORMATION

## METRIC

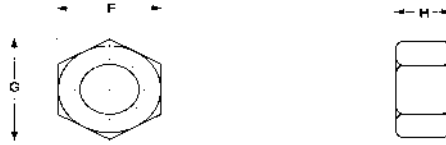

### HEX NUTS

Nominal Size	Thread Pitch	F		G	H	
		Max	Min	Width Across Corners	Thickness	
M1.6	0.35	3.2	3.02	3.41	1.3	1.05
M2	0.4	4	3.82	4.32	1.6	1.35
M2.5	0.45	5	4.82	5.45	2	1.75
M3	0.5	5.5	5.32	6.01	2.4	2.15
M4	0.7	7	6.78	7.66	3.2	2.9
M5	0.8	8	7.78	8.79	4.7	4.4
M6	1	10	9.78	11.05	5.2	4.9
M8	1.25	13	12.73	14.38	6.8	6.44
M10	1.5	16	15.73	17.77	8.4	8.04
M12	1.75	18	17.73	20.03	10.8	10.37
M14	2	21	20.67	23.35	12.8	12.1
M16	2	24	23.67	26.75	14.8	14.1
M20	2.5	30	29.16	32.95	18	16.9
M24	3	36	35	39.55	21.5	20.2
M30	3.5	46	45	50.85	25.6	24.3
M36	4	55	53.8	60.79	31	29.4
M42	4.5	65	63.1	71.30	34	32.4
M48	5	75	73.1	82.60	38	36.4
M56	5.5	85	82.8	93.56	45	43.4
M64	6	95	92.8	104.86	51	49.1

### JAM NUTS

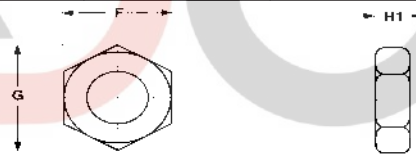

Nominal Size	Thread Pitch	F		G	H	
		Max	Min	Width Across Corners	Max	Min
M1.6	0.35	3.2	3.02	3.41	1	0.75
M2	0.4	4	3.82	4.32	1.2	0.95
M2.5	0.45	5	4.82	5.45	1.6	1.35
M3	0.5	5.5	5.32	6.01	1.8	1.55
M4	0.7	7	6.78	7.66	2.2	1.95
M5	0.8	8	7.78	8.79	2.7	2.45
M6	1	10	9.78	11.05	3.2	2.9
M8	1.25	13	12.73	14.38	4	3.7
M10	1.5	16	15.73	17.77	5	4.7
M12	1.75	18	17.73	20.03	6	5.7
M14	2	21	20.67	23.35	7	6.42
M16	2	24	23.67	26.75	8	7.42
M20	2.5	30	29.16	32.95	10	9.10
M24	3	36	35	39.55	12	10.9
M30	3.5	46	45	50.85	15	13.9
M36	4	55	53.8	60.79	18	16.9
M42	4.5	65	63.1	71.30	21	19.70
M48	5	75	73.1	82.60	24	22.7



## TECHNICAL INFORMATION

A-37

### METRIC FLAT WASHERS

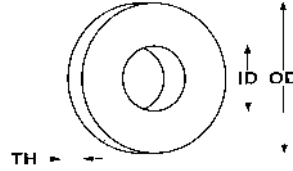

### METRIC - STANDARD FLAT WASHERS (NORMAL SERIES, GRADE A)

Nominal Size	ID		OD		T	
	Internal Diameter		Outside Diameter		Thickness	
	Max	Min	Max	Min	Max	Min
1.6	1.84	1.7	4	3.7	0.35	0.25
2	2.34	2.2	5	4.7	0.35	0.25
2.5	2.84	2.7	6	5.7	0.55	0.45
3	3.38	3.2	7	6.64	0.55	0.45
3.5	3.88	3.7	8	7.64	0.55	0.45
4	4.48	4.3	9	8.64	0.9	0.7
5	5.48	5.3	10	9.64	1.1	0.9
6	6.62	6.4	12	11.57	1.8	1.4
8	8.62	8.4	16	15.57	1.8	1.4
10	10.77	10.5	20	19.48	2.2	1.8
12	13.27	13	24	23.48	2.7	2.3
14	15.27	15	28	27.48	2.7	2.3
16	17.27	17	30	29.48	3.3	2.7
20	21.33	21	37	36.38	3.3	2.7
24	25.33	25	44	43.38	4.3	3.7
30	31.39	31	56	55.26	4.3	3.7
36	37.62	37	66	64.8	5.6	4.4

### METRIC SPLIT LOCK WASHERS



Nominal Washer Size	A		B	T	W
	Inside Diameter		Outside Diameter	Section Thickness	Section Width
	Max	Min	Ref	Ref	Ref
M2	2.4	2.1	4.4	0.50	0.9
M2.5	2.9	2.6	5.1	0.60	1
M3	3.4	3.1	6.2	0.80	1.3
M4	4.4	4.1	7.6	0.90	1.5
M5	5.4	5.1	9.2	1.20	1.8
M6	6.5	6.1	11.8	1.60	2.5
M8	8.5	8.1	14.8	2	3
M10	10.7	10.2	18.1	2.2	3.5
M12	12.7	12.2	21.1	2.5	4
M16	17.0	16.2	27.4	3.5	5
M20	21.2	20.2	33.6	4	6
M24	25.5	24.5	40	5	7
M30	31.7	30.5	48.2	6	8
M36	37.7	36.5	58.2	6	10
M42	43.7	42.5	68.2	7	12
M48	50.5	49	75	7	12

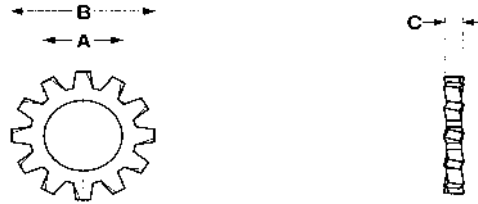

**METRIC**

**EXTERNAL TOOTH LOCK WASHER**

Nominal Size	A		B		C		Preferred Number of Teeth*
	Inside Diameter		Outside Diameter		Thickness		
	Max	Min	Max	Min	Max	Min	
M3	3.4	3.2	6.5	6.1	0.485	0.415	8
M3.5	3.9	3.7	7.5	7.1	0.485	0.415	8
M4	4.5	4.3	8.5	8.1	0.485	0.415	9
M5	5.5	5.3	10	9.6	0.64	0.56	10
M6	6.7	6.4	11	10.5	0.64	0.56	12
M8	8.7	8.4	15	14.5	0.85	0.75	12
M10	10.9	10.5	18	17.5	0.95	0.85	12
M12	12.9	12.5	21	20.4	1.055	0.945	12
M14	14.9	14.5	23	22.4	1.055	0.945	12
M16	16.9	16.5	26	25.4	1.265	1.135	14
M20	21.5	21	32	31.2	1.47	1.33	14

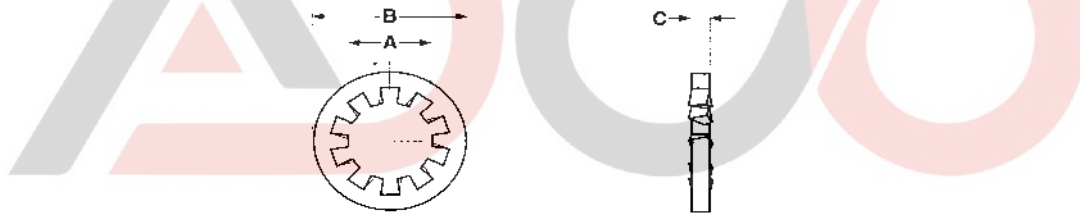
\* Slight deviation from the preferred number of teeth is permitted.

**INTERNAL TOOTH LOCK WASHERS**

Nominal Size	A		B		C		Preferred Number of Teeth*
	Inside Diameter		Outside Diameter		Thickness		
	Max	Min	Max	Min	Max	Min	
M2	2.4	2.2	4.8	4.5	0.325	0.275	7
M2.5	2.9	2.7	5.7	5.4	0.325	0.275	7
M3	3.4	3.2	6.5	6.1	0.485	0.415	8
M3.5	3.9	3.7	7.5	7.1	0.485	0.415	8
M4	4.5	4.3	8.5	8.1	0.485	0.415	8
M5	5.5	5.3	10	9.6	0.64	0.56	8
M6	6.7	6.4	11	10.5	0.64	0.56	9
M8	8.7	8.4	15	14.5	0.85	0.75	9
M10	10.9	10.5	18	17.5	0.95	0.85	9
M12	12.9	12.5	21	20.4	1.055	0.945	10
M14	14.9	14.5	23	22.4	1.055	0.945	10
M16	16.9	16.5	26	25.4	1.265	1.135	12
M20	21.5	21	32	31.2	1.47	1.33	12

\* Slight deviation from the preferred number of teeth is permitted.





# TECHNICAL INFORMATION

A-39

## METRIC

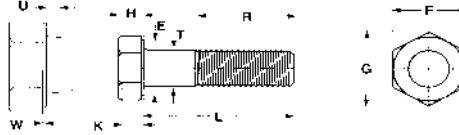

### HEX HEAD BOLTS

Nominal Size	Thread Pitch	R		W		T	U	E	H		F		G	K
		Threaded Length		Washer Face Thickness		Fillet Transition Diameter	Under-head Fillet	Washer Face Diameter	Head Height		Width Across Flats		Width Across Corners	Wrenching Height
		L ≤ 125 mm	L > 125 mm ≤ 200 mm	Max	Min	Max	Max	Min	Max	Min	Max	Min	Min	Min
M1.6	0.35	9	-	0.25	0.1	2	0.6	2.27	1.225	0.975	3.2	3.02	3.41	0.68
M2	0.4	10	-	0.25	0.1	2.6	0.8	3.07	1.525	1.275	4	3.82	4.32	0.89
M2.5	0.45	11	-	0.25	0.1	3.1	1	4.07	1.825	1.575	5	4.82	5.45	1.1
M3	0.5	12	-	0.4	0.15	3.6	1	4.57	2.125	1.875	5.5	5.32	6.01	1.31
M4	0.7	14	-	0.4	0.15	4.7	1.2	5.88	2.925	2.675	7	6.78	7.66	1.87
M5	0.8	16	-	0.5	0.15	5.7	1.2	6.88	3.65	3.35	8	7.78	8.79	2.35
M6	1	18	-	0.5	0.15	6.8	1.4	8.88	4.15	3.85	10	9.78	11.05	2.7
M8	1.25	22	-	0.6	0.15	9.2	2	11.63	5.45	5.15	13	12.73	14.38	3.61
M10	1.5	26	-	0.6	0.15	11.2	2	14.63	6.58	6.22	16	15.73	17.77	4.35
M12	1.75	30	-	0.6	0.15	13.7	3	16.63	7.68	7.32	18	17.73	20.03	5.12
M14	2	34	40	0.6	0.15	15.7	3	19.37	8.98	8.62	21	20.67	23.36	6.03
M16	2	38	44	0.8	0.2	17.7	3	22.49	10.18	9.82	24	23.67	26.75	6.87
M20	2.5	46	52	0.8	0.2	22.4	4	28.19	12.715	12.285	30	29.67	33.53	8.6
M24	3	54	60-73	0.8	0.2	26.4	4	33.61	15.215	14.785	36	35.38	39.98	10.35

### HEX HEAD CAP SCREWS FULL THREAD



Nominal Size	Thread Pitch	A		W		T	E	H		F		G	K
		Thread Run-Out		Washer Face Thickness		Fillet Transition Diameter	Washer Face Diameter	Head Height		Width Across Flats		Width Across Corners	Wrenching Height
		Max	Min	Max	Min	Max	Min	Max	Min	Max	Min	Min	Min
M1.6	0.35	1.05	0.35	0.25	0.1	2	2.27	1.225	0.975	3.2	3.02	3.41	0.68
M2	0.4	1.2	0.4	0.25	0.1	2.6	3.07	1.525	1.275	4	3.82	4.32	0.89
M2.5	0.45	1.35	0.45	0.25	0.1	3.1	4.07	1.825	1.575	5	4.82	5.45	1.1
M3	0.5	1.5	0.5	0.4	0.15	3.6	4.57	2.125	1.875	5.5	5.32	6.01	1.31
M4	0.7	2.1	0.7	0.4	0.15	4.7	6.03	2.925	2.675	7	6.78	7.66	1.87
M5	0.8	2.4	0.8	0.5	0.15	5.7	6.88	3.65	3.35	8	7.78	8.79	2.35
M6	1	3	1	0.5	0.15	6.8	8.88	4.15	3.85	10	9.78	11.05	2.7
M8	1.25	4	1.25	0.6	0.15	9.2	11.63	5.45	5.15	13	12.73	14.38	3.61
M10	1.5	4.5	1.5	0.6	0.15	11.2	14.63	6.58	6.22	16	15.73	17.77	4.35
M12	1.75	5.3	1.75	0.6	0.15	13.7	16.63	7.68	7.32	18	17.73	20.03	5.12
M14	2	6	2	0.6	0.15	15.7	19.37	8.98	8.62	21	20.67	23.36	6.03
M16	2	6	2	0.8	0.2	17.7	22.49	10.18	9.82	24	23.67	26.75	6.87
M20	2.5	7.5	2.5	0.8	0.2	22.4	28.19	12.715	12.285	30	29.67	33.53	8.6
M24	3	9	3	0.8	0.2	26.4	33.61	15.215	14.785	36	35.38	39.98	10.35

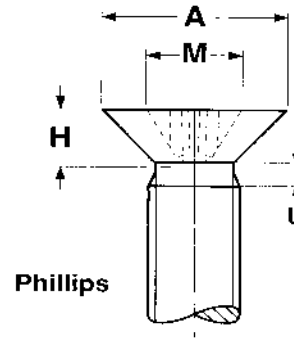
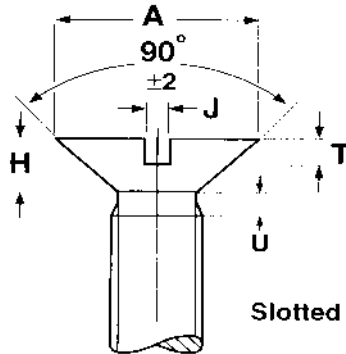

**A-40**
**TECHNICAL INFORMATION**
**METRIC FLAT HEAD MACHINE SCREWS**

**METRIC - SLOTTED FLAT HEAD MACHINE SCREWS**

Nominal Size	Thread Pitch	A		H	J		T		U
		Head Diameter		Head Height	Width of Slot		Depth of Slot		Thread Runout
		Max	Min	Max	Max	Min	Max	Min	Max
M1.6	0.35	3.0	2.7	1	0.60	0.46	0.50	0.32	0.7
M2	0.4	3.8	3.5	1.2	0.70	0.56	0.60	0.4	0.8
M2.5	0.45	4.7	4.4	1.5	0.80	0.66	0.75	0.50	0.9
M3	0.5	5.5	5.2	1.65	1.00	0.86	0.85	0.60	1
M4	0.7	8.40	8.04	2.7	1.51	1.26	1.3	1.0	1.4
M5	0.8	9.30	8.94	2.7	1.51	1.26	1.4	1.1	1.6
M6	1	11.30	10.87	3.3	1.91	1.66	1.6	1.2	2
M8	1.25	15.80	15.37	4.65	2.31	2.06	2.3	1.8	2.5
M10	1.5	18.30	17.78	5	2.81	2.56	2.6	2.0	3

**METRIC - PHILLIPS FLAT HEAD MACHINE SCREWS**

Nominal Size	Thread Pitch	A		H	M	G		U	Phillips Driver Size
		Head Diameter		Head Height	Recess Diameter	Recess Penetration		Thread Runout	
		Max	Min	Max	Ref	Max	Min	Max	
M1.6	0.35	3.0	2.7	1	1.6	0.9	0.6	0.7	0
M2	0.4	3.8	3.5	1.2	1.9	1.2	0.9	0.8	0
M2.5	0.45	4.7	4.4	1.5	2.9	1.8	1.4	0.9	1
M3	0.5	5.5	5.2	1.65	3.2	2.1	1.7	1	1
M3.5	0.6	7.3	6.9	2.35	4.4	2.4	1.9	1.2	2
M4	0.7	8.40	8.04	2.7	4.6	2.6	2.1	1.4	2
M5	0.8	9.30	8.94	2.7	5.2	3.2	2.7	1.6	2
M6	1	11.30	10.87	3.3	6.8	3.5	3.0	2	3
M8	1.25	15.80	15.37	4.65	8.9	4.6	4.0	2.5	4
M10	1.5	18.30	17.78	5	10	5.7	5.1	3	4



# TECHNICAL INFORMATION

# A-41

## METRIC OVAL HEAD MACHINE SCREWS

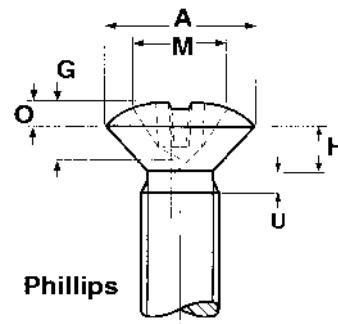
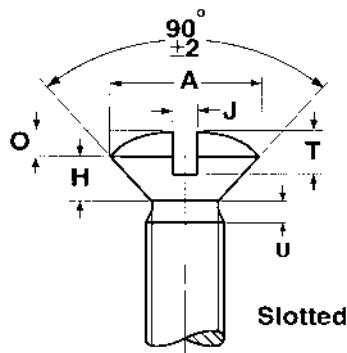

### SLOTTED OVAL HEAD MACHINE SCREWS

Nominal Size	Thread Pitch	A		H	O	J		T		U
		Head Diameter		Head Side Height	Height of Oval	Width of Slot		Depth of Slot		Thread Runout
		Max	Min	Max	Ref	Max	Min	Max	Min	Max
M1.6	0.35	3.0	2.7	1	0.4	0.60	0.46	0.80	0.64	0.7
M2	0.4	3.8	3.5	1.2	0.5	0.70	0.56	1.0	0.8	0.8
M2.5	0.45	4.7	4.4	1.5	0.6	0.80	0.66	1.2	1.0	0.9
M3	0.5	5.5	5.2	1.65	0.7	1.00	0.86	1.45	1.20	1
M4	0.7	8.40	8.04	2.7	1	1.51	1.26	1.9	1.6	1.4
M5	0.8	9.30	8.94	2.7	1.2	1.51	1.26	2.4	2.0	1.6
M6	1	11.30	10.87	3.3	1.4	1.91	1.66	2.8	2.4	2
M8	1.25	15.80	15.37	4.65	2	2.31	2.06	3.7	3.2	2.5
M10	1.5	18.30	17.78	5	2.3	2.81	2.56	4.4	3.8	3

### PHILLIPS OVAL HEAD MACHINE SCREWS

Nominal Size	Thread Pitch	A		H	O	M	G		U	Phillips Driver Size
		Head Diameter		Head Side Height	Height of Oval	Recess Width	Recess Penetration		Thread Runout	
		Max	Min	Max	Ref	Ref	Max	Min	Max	
M1.6	0.35	3.0	2.7	1	0.4	1.9	1.2	0.9	0.7	0
M2	0.4	3.8	3.5	1.2	0.5	2	1.5	1.2	0.8	0
M2.5	0.45	4.7	4.4	1.5	0.6	3	1.85	1.50	0.9	1
M3	0.5	5.5	5.2	1.65	0.7	3.4	2.2	1.8	1	1
M4	0.7	8.40	8.04	2.7	1	5.2	3.2	2.7	1.4	2
M5	0.8	9.30	8.94	2.7	1.2	5.4	3.4	2.9	1.6	2
M6	1	11.30	10.87	3.3	1.4	7.3	4.0	3.5	2	3
M8	1.25	15.80	15.37	4.65	2	9.6	5.25	4.75	2.5	4
M10	1.5	18.30	17.78	5	2.3	10.4	6.0	5.5	3	4



# A-42

# TECHNICAL INFORMATION

## METRIC PAN HEAD MACHINE SCREWS

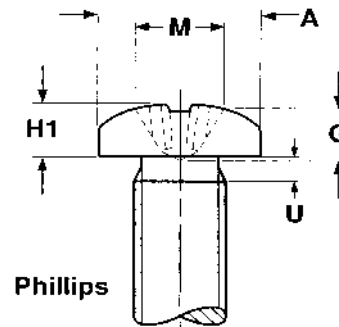
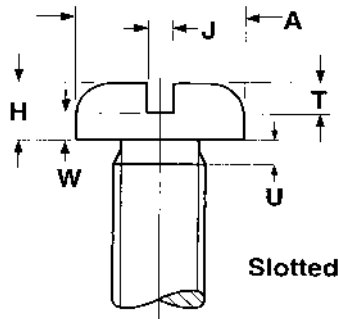

### METRIC - SLOTTED PAN HEAD MACHINE SCREWS

Nominal Size	Thread Pitch	A		H		J		T	W	U
		Head Diameter		Head Height		Width of Slot		Depth of Slot	Wall Thickness	Thread Runout
		Max	Min	Max	Min	Max	Min	Min	Min	Max
M1.6	0.35	3.2	2.9	1.00	0.86	0.60	0.46	0.35	0.3	0.7
M2	0.4	4.0	3.7	1.30	1.16	0.70	0.56	0.5	0.4	0.8
M2.5	0.45	5.0	4.7	1.50	1.36	0.80	0.66	0.6	0.5	0.9
M3	0.5	5.6	5.3	1.80	1.66	1.00	0.86	0.7	0.7	1
M4	0.7	8.00	7.64	2.40	2.26	1.51	1.26	1	1	1.4
M5	0.8	9.50	9.14	3.00	2.86	1.51	1.26	1.2	1.2	1.6
M6	1	12.00	11.57	3.6	3.3	1.91	1.66	1.4	1.4	2
M8	1.25	16.00	15.57	4.8	4.5	2.31	2.06	1.9	1.9	2.5
M10	1.5	20.00	19.48	6.0	5.7	2.81	2.56	2.4	2.4	3

### METRIC - PHILLIPS PAN HEAD MACHINE SCREWS

Nominal Size	Thread Pitch	A		H1		M	G		U	Phillips Driver Size
		Head Diameter		Height of Head		Recess Diameter	Recess Penetration		Thread Runout	
		Max	Min	Max	Min	Ref	Max	Min	Max	
M1.6	0.35	3.2	2.9	1.30	1.16	1.7	0.95	0.70	0.7	0
M2	0.4	4.0	3.7	1.60	1.46	1.9	1.2	0.9	0.8	0
M2.5	0.45	5.0	4.7	2.10	1.96	2.7	1.55	1.15	0.9	1
M3	0.5	5.6	5.3	2.40	2.26	3	1.8	1.4	1	1
M3.5	0.6	7.00	6.64	2.60	2.46	3.9	1.9	1.4	1.2	2
M4	0.7	8.00	7.64	3.10	2.92	4.4	2.4	1.9	1.4	2
M5	0.8	9.50	9.14	3.70	3.52	4.9	2.9	2.4	1.6	2
M6	1	12.00	11.57	4.6	4.3	6.9	3.6	3.1	2	3
M8	1.25	16.00	15.57	6.0	5.7	9	4.6	4.0	2.5	4
M10	1.5	20.00	19.48	7.50	7.14	10.1	5.8	5.2	3	4



# TECHNICAL INFORMATION

# A-43

## METRIC SOCKET PRODUCTS

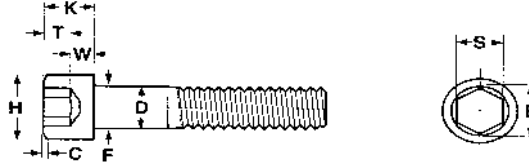

### METRIC - SOCKET HEAD CAP SCREWS, CLASS 12.9

Basic Screw Diameter	Thread Pitch	D		H		K		C	F	S		E	T	W
		Body Diameter		Head Diameter		Head Height		Top Chamfer of Radius	Fillet Transition Diameter	Socket Size Across the Flats		Socket Size Across the Corners	Key Engagement	Wall Thickness
		Max	Min	Max	Min	Max	Min	Max	Max	Max	Max	Min	Min	Min
M1.6	0.35	1.60	1.46	3.14	2.86	1.60	1.46	0.16	2	1.545	1.520	1.73	0.7	0.55
M2	0.4	2.00	1.86	3.98	3.62	2.00	1.86	0.2	2.6	1.545	1.520	1.73	1	0.55
M2.5	0.45	2.50	2.36	4.68	4.32	2.50	2.36	0.25	3.1	2.045	2.020	2.3	1.1	0.85
M3	0.5	3.00	2.86	5.68	5.32	3.00	2.86	0.3	3.6	2.56	2.52	2.87	1.3	1.15
M4	0.7	4.00	3.82	7.22	6.78	4.00	3.82	0.4	4.7	3.071	3.020	3.44	2	1.4
M5	0.8	5.00	4.82	8.72	8.28	5.00	4.82	0.5	5.7	4.084	4.020	4.58	2.5	1.9
M6	1	6.00	5.82	10.22	9.78	6.00	5.7	0.6	6.8	5.084	5.020	5.72	3	2.3
M8	1.25	8.00	7.78	13.27	12.73	8.00	7.64	0.8	9.2	6.095	6.020	6.86	4	3.3
M10	1.5	10.00	9.78	16.27	15.73	10.00	9.64	1	11.2	8.115	8.025	9.15	5	4
M12	1.75	12.00	11.73	18.27	17.73	12.00	11.57	1.2	13.7	10.115	10.025	11.43	6	4.8
M16	2	16.00	15.73	24.33	23.67	16.00	15.57	1.6	17.7	14.142	14.032	16	8	6.8
M20	2.5	20.00	19.67	30.33	29.67	20.00	19.48	2	22.4	17.23	17.05	19.44	10	8.6
M24	3	24.00	23.67	36.39	35.61	24.00	23.48	2.4	26.4	19.275	19.065	21.73	12	10.4
M30	3.5	30.00	29.67	45.39	44.61	30.00	29.48	3	33.4	22.275	22.065	25.15	15.5	13.1
M36	4	36.00	35.61	54.46	53.54	36.00	35.38	3.6	39.4	27.275	27.065	30.85	19	15.3
M42	4.5	42.00	41.61	63.46	62.54	42.00	41.38	4.2	45.6	32.33	32.08	36.57	24	16.3
M48	5	48.00	47.61	72.46	71.54	48.00	47.38	4.8	52.6	36.33	36.08	41.13	28	17.5
M56	5.5	56.00	55.54	84.54	83.46	56.00	55.26	5.6	63	41.33	41.08	46.83	34	19
M64	6	64.00	63.54	96.54	95.46	64.00	63.26	6.4	71	46.33	46.08	52.53	38	22

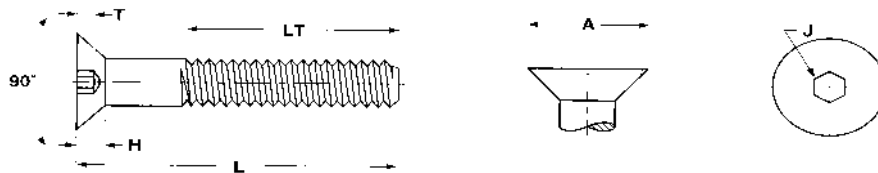

### METRIC - FLAT HEAD SOCKET CAP SCREWS, CLASS 10.9

Nominal Size	Thread Pitch	B		A		H		J	T	W	D
		Body Diameter		Head Diameter		Head Height		Hex Socket Size	Key Engagement	Wall Thickness	Drill Allowance
		Max	Min	Theoretical Sharp	Absolute Min	Ref	Flush Tolerance	Nom	Min	Min	Max
M3	0.5	3.00	2.86	6.72	5.35	1.86	0.30	2.0	1.1	0.25	0.3
M4	0.7	4.00	3.82	8.96	7.80	2.48	0.30	2.5	1.5	0.45	0.4
M5	0.8	5.00	4.82	11.20	9.75	3.10	0.35	3.0	1.9	0.66	0.5
M6	1	6.00	5.82	13.44	11.70	3.72	0.35	4.0	2.2	0.70	0.6
M8	1.25	8.00	7.78	17.92	15.60	4.96	0.40	5.0	3.0	1.16	0.8
M10	1.5	10.00	9.78	22.40	19.50	6.20	0.50	6.0	3.6	1.62	0.9

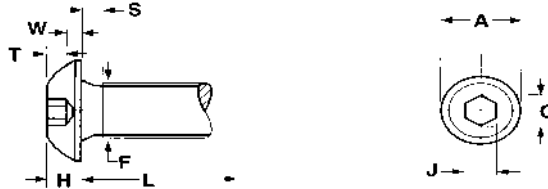

**A-44**
**TECHNICAL INFORMATION**
**METRIC SOCKET PRODUCTS**

**METRIC - BUTTON HEAD SOCKET CAP SCREWS, CLASS 10.9**

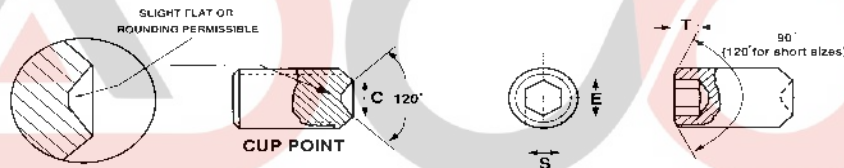
Nominal Size	Thread Pitch	A		H		C		J		T	W	S		F	Min Ultimate Tensile Load, N
		Head Diameter		Head Height		Socket Size Across the Corners		Socket Size Across the Flats		Key Engagement	Wall Thickness	Unthreaded Section Under the Head		Fillet Transition Diameter	
		Max	Min	Max	Min	Min	Max	Min	Min	Min	Max	Min	Max		
M3	0.5	5.7	5.4	1.65	1.40	2.3	2.045	2.020	1.04	1.04	0.2	1.0	0.5	3.6	4,910
M4	0.7	7.60	7.24	2.20	1.95	2.87	2.56	2.52	1.3	1.3	0.3	1.4	0.7	4.7	8,560
M5	0.8	9.50	9.14	2.75	2.50	3.44	3.071	3.020	1.56	1.56	0.38	1.6	0.8	5.7	13,800
M6	1	10.50	10.07	3.3	3.0	4.58	4.084	4.020	2.08	2.08	0.74	2	1	6.8	19,600
M8	1.25	14.00	13.57	4.4	4.1	5.72	5.084	5.020	2.6	2.6	1.05	2.50	1.25	9.2	35,700
M10	1.5	17.50	17.07	5.5	5.2	6.86	6.095	6.020	3.12	3.12	1.45	3.0	1.5	11.2	56,600
M12	1.75	21.00	20.48	6.60	6.24	9.15	8.115	8.025	4.16	4.16	1.63	3.50	1.75	14.2	82,400
M16	2	28.00	27.48	8.80	8.44	11.43	10.115	10.025	5.2	5.2	2.25	4	2	18.2	154,000

**METRIC - SOCKET SET SCREWS, CUP POINT**











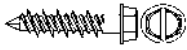

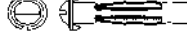
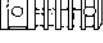

Nominal Size	Thread Pitch	C		E	S		Screws Below this Length are Short Sizes	T		Min Length of Screw for Torque Test	Test Torque N. m
		Point Diameter		Socket Size Across Corners	Socket Size Across the Flats			Key Engagement (Min)			
		Max	Min	Min	Max	Min		Short Sizes	Long Sizes		
M1.6	0.35	0.80	0.55	0.803	0.724	0.711	2.5	0.7	1.5	-	-
M2	0.4	1.00	0.75	1.003	0.902	0.889	3	0.8	1.7	-	-
M2.5	0.45	1.20	0.95	1.427	1.295	1.270	4	1.2	2	-	-
M3	0.5	1.40	1.15	1.73	1.545	1.520	5	1.2	2	4	0.9
M4	0.7	2.00	1.75	2.3	2.045	2.020	6	1.5	2.5	5	2.5
M5	0.8	2.50	2.25	2.87	2.560	2.520	6	2	3	6	5
M6	1	3.00	2.75	3.44	3.071	3.020	8	2	3.5	8	8.5
M8	1.25	5.0	4.7	4.58	4.084	4.020	10	3	5	10	20
M10	1.5	6.0	5.7	5.72	5.084	5.020	12	4	6	12	40
M12	1.75	8.00	7.64	6.86	6.095	6.020	16	4.8	8	16	65
M16	2	10.00	9.64	9.15	8.115	8.025	20	6.4	10	20	160
M20	2.5	14.00	13.57	11.43	10.115	10.025	25	8	12	25	310
M24	3	16.00	15.57	13.72	12.142	12.032	30	10	15	30	520

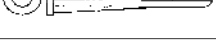

# TECHNICAL INFORMATION

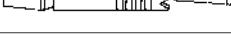
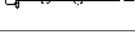
A-45

## ANCHOR INFORMATION

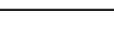
Anchor	Type	Use In
	Concrete - Masonry Anchors	Concrete, Block, Brick & Masonry
	Drive Anchors	Concrete, Block & Brick
	Drop-In Anchors Steel & Stainless	Concrete & Stone
	E-Z Toggle Anchors	Wallboard
	Hollow Wall Anchors	Wallboard, Hollow Plaster & Tile Block
	Lag Screw Shields	Mortar Joint or Concrete
	Machine Screw Anchors	Concrete, Brick & Stone
	Non-Drilling Anchors	Concrete, Brick & Stone
	One Step Wallboard Anchors	Wallboard
	Plastic Anchors	Concrete, Brick, Block & Stone
	Plastic Screw Anchors	Concrete, Brick, Block & Wallboard
	Polly Toggle Anchors	Wallboard or Solid Masonry
	Self-Drilling Shields	Concrete
	Sleeve Anchors	Concrete, Stone & Brick
	Stud Anchors	Concrete, Brick & Stone
	Toggle Bolts	Hollow block, Wallboard & Plaster
	Wedge Anchors	Concrete or Stone
	Wood Screw Shields	Concrete, Block & Brick



**ANCHOR DRILLING INFORMATION**

Description	Diameter of Anchor	Drill Hole Size	Diameter of Anchor	Drill Hole Size
Drop in Anchors	1/4	3/8	5/8	7/8
	3/8	1/2	3/4	1
	1/2	5/8		
Lag Shields	1/4	1/2	1/2	3/4
	5/16	1/2	5/8	7/8
	3/8	5/8	3/4	1
Lead Wood Screw Anchors	#6	1/4	#16	3/8
	#10	5/16		
Lead Machine Screw Anchors, Single	6/32	5/16	3/8	3/4
	8/32	5/16	1/2	7/8
Expansion Shields & Double Expansion Shields	10/24	3/8	5/8	1 1/8
	1/4	1/2	3/4	1 1/4
	5/16	5/8		
Plastic Conical Anchors	6-8	3/16	10-12	1/4
	8-10	3/16	14-16	5/16
Toggle Bolts	1/8	3/8	5/16	7/8
	3/16	1/2	3/8	1
	1/4	5/8	1/2	1 1/4
Hollow Wall Anchors	1/8 - All Sizes	5/16	1/4 - S	7/16
	3/16-S	3/8	1/4 - L	7/16
	3/16-L	3/8	1/4 - XL	1/2
	3/16-XL	7/16		

Nail Drives Nylon Nail Anchors Sleeve Anchors Split Drive Anchors Wedge Anchors	Drill hole is the same as the diameter of the anchor product.
Hollow Wall Drive Anchors	No Drilling Required
Plastic Drive Anchors	No Drilling Required





## TECHNICAL INFORMATION

## A-47

### STAINLESS STEEL SPECIFICATIONS

- Type 301:** Cr. 18, Ni. 8 (18-8 type), austenitic, hardenable by cold work only; t.s., 80-270,000 psi; y.s.30-240,000 psi; elongation in 2", 40-5%. In rods, bars, billets, wire, sheet, plate, strip and tubing. For parts requiring good corrosion resistance combined with high tensile strength and good ductility.
- Type 302:** Cr. 18, Ni. 8 (18-8 type), austenitic, hardenable by cold work only; t.s. 80-250,000 psi; y.s. 30-225,000 psi; elongation in 2", 60-5%; fair machinability excellent cold forming and welding properties. Furnished in sheet, strip, plate, bar, rod, forging billets and tube rounds, tubing, cold drawn shapes and structural shapes. For parts in acid handling food and dairy equipment; shafting, bearing plates, heat exchanger tubes, hydraulic tubing, piston rods, plungers, etc.
- Type 303:** Cr. 18, Ni. 8 (18-8 type), austenitic, hardenable by cold work only; t.s., 80-200,000 psi; y.s. 30-135,000 psi; elong. in 2", 55-10% good machinability; fair cold forming and welding properties. In sheet, strip, plate, bar, rod, forging billets, tube rounds, tubing, cold drawn and structural shapes. For working parts in pumps and valves which must resist corrosion; screw machine parts requiring strength, good corrosion resistance.
- Type 304:** Cr. 18, Ni. 8 (18-8 type), austenitic, hardenable by cold work only; t.s., 85-250,000 psi; y.s., 30-225,000 psi; elongation in 2", 60-5%; slightly better corrosion resistance than Type 302. Furnished in rods, bars, billets, wire, sheet, plate strip, tubing and castings. For parts in chemical equipment such as shafting, bearing plates, heat exchanger tubes, etc.
- Type 309:** Cr. 25, Ni. 12 (25-12 type), austenitic, hardenable by cold work only; t.s., 95-190,000 psi; y.s. 45-165,000 psi; elong. in 2 inches, 50-5%; resists scaling to 2000°F, fair machinability, good cold C forming properties, excellent weldability. Furnished in sheet, strip, plate, bar, rod, forging billets, tube rounds, tubing, cold drawn shapes and structural shapes. For parts that must operate continuously at high temperatures; oil burner parts, furnace parts, heat exchangers, air heaters, battle plates, etc.
- Type 310:** Cr. 25, Ni. 20(25-20 type), austenitic, hardenable by cold work only, t.s., annealed, 70-155,000 psi; elong. in 2", 55-5%; good weldability, drawing, stamping properties; fair machinability. In sheet, strip, plate, bar, rod, forging billet, tube rounds, tubing, cold drawn, structural shapes. For parts subject to intermittent heating and cooling; oil burner parts, heat exchangers; dye house, paper mill, chemical equipment.
- Type 316:** Cr. 18, Ni. 12, No. 3 (18-12-3 type), austenitic, hardenable by cold work only, t.s., 80-170,000 psi; y.s., 35-150,000 psi; elong. in 2", 55-5% fair machinability; excellent welding, cold forming properties. Best creep strength at high temp. and best corrosion resistance of all grades. In sheet, strip, plate, bar, rod, forging billets, tube rounds, tubing, cold drawn and structural shapes.
- Type 321:** Cr. 18, Ni. 8, Ti. 4 x C min.: austenitic, hardenable by cold work only; t.s., 80-170,000 psi; y.s., 30-145,000 psi; elong. in 2", 55-5%; fair machinability, excellent welding, cold forming properties. In sheet, strip, plate, bar, rod, forging billets, tube rounds, tubing, cold drawn shapes, structural shapes. For welded parts not annealed after welding or which operate at 800-1200°F; aircraft engine exhaust rings, flanges, etc.
- Type 347:** Cr. 18, Ni. 8, Cr 8 x C min.: austenitic, hardenable by cold work only; t.s., 80-170,000 psi; y.s., 30-150,000 psi; elong. in 2", 50-5%; fair machinability, excellent welding, cold forming properties. In sheet, strip, plate, bar, rod, forging billets, tube rounds, tubing, cold drawn shapes and structural shapes. For welded parts not annealed after welding or which operate at 800-1200°F; aircraft engine exhaust rings, Ranges, etc.
- Type 410:** Cr. 12 (straight chromium type), hardenable by heat treatment; t.s., 60-180,000 psi; 30-160,000 psi; elong. in 2", 30-15%; good machinability, cold forming properties: good welding properties when annealed; most popular forging grade. In sheet, strip, plate, bar, rod, forging billets, tube rounds, tubing, cold drawn and structural shapes. Used where corrosion not severe, for bolts, nuts, shafting turbine blading, valve trim, heat-treated parts; where hardness, toughness, desired.
- Type 416:** Cr. 12 (straight chromium type with sulphur or selenium added); excellent machinability; t.s., 70-170,000 psi; y.s., 4-140,000 psi; elong. in 2", 30-10%; fair cold forming properties, fair corrosion resistance. In bar, rod, forging billets, wire, cold drawn shapes. For mass production machined parts; Carburetor, instrument and electrical parts; screw machine parts.
- Type 420:** Cr. 13, C. 35; a widely used stainless cutlery steel. In the hardened and tempered condition, it combines an adequate hardness and cutting edge with good flexibility. It retains a bright polished finish and can be hardened to Rockwell C 55. Maximum corrosion resistance is obtained in the hardened condition.
- Type 420F:** Cr. 13, C. 35; free machining; has sulphur intentionally added to the base Type 420 analysis to make it easier to machine, grind and polish. Type 420°F has practically the same mechanical hardness, and corrosion resisting properties as Type 420.
- Type 430:** Cr. 17 (straight chromium type), non-hardenable by heat treatment; resists scaling to 1500°F; excellent cold heading properties, excellent machinability; does not discolor in atmosphere. t.s., 60-85,000 psi; y.s. 35-55,000 psi; elongation in 2", 35-20%. Furnished in sheet, strip, plate, bar, rod, forging billets, tube rounds, tubing, cold drawn shapes and structural shapes. For press plates, oil burner parts, screw machine parts, trim for automobiles such as body moldings, hub caps, finishing washers, gas tank caps, etc.; also trim for appliances.
- Type 430F:** Cr. 17 with 0.07 S. or Se.; straight chromium free machining type, non-hardenable by heat treatment; t.s., 60-85,000 psi; 35-55,000 psi; elong. in 2", 25-10%; excellent machinability, fair cold forming properties. In forging billets, hot-rolled and cold-finished bars, wire and polished shafting. Particularly suitable for parts requiring considerable machining and only moderate corrosion resistance; screw machine parts.
- Type 431:** Cr. 16, Ni. 2 (straight chromium type), hardenable by heat treatment; t.s., 110-200,000 psi; 80-150,000 psi; elongation in 2", 20-15%; good machinability; fair cold forming properties; resists scaling to 1500°F. Best corrosion resistance of all hardenable stainless steels. Furnished in sheet, strip, plate, bar, rod, forging billets, tube rounds, tubing, cold drawn shapes, structural shapes. For parts requiring excellent physical properties coupled with high corrosion resistance.
- Type 440 C and 440 A, B and C:** Cr. 17, C 1.00 (straight chromium type), hardenable by heat treatment; t.s., 110-285,000 psi; 60-275,000 psi; elong. in 2", 15-21%; fair machinability, cold forming properties. Types A, B, same analysis except for lower carbon content: less hardenable; Type F, free machining. In sheet, strip, plate, bar, rod, forging billets, tube round tubing, cold drawn and structural shapes; needle, ball check valves; ball bearings, scissors, rules, cutlery, etc.
- Type 501 and 502:** Type 501, 4/6 Cr. plus Mo. over. 10 C. Type 502, 4/6 Cr. plus Mo., over. 10 C. maximum. Both types are recommended for use in the petroleum industry. In refinery equipment, particularly where sour crudes are encountered a life of four to ten times that of mild steel is not uncommon. These alloys are suitable for use at slightly elevated temperature, and are more resistant to scaling or oxidation than is mild steel. Scaling temperature about 1150° Fahrenheit.



**FASTENER HOLE GUIDE**

Drill This Size Hole		To Tap For This Size Bolt or Screw	For This Size Wood Screw Pilot In Hard Wood	Drill This Size Hole		To Tap For This Size Bolt or Screw	For This Size Wood Screw Pilot In Hard Wood	Drill This Size Hole		To Tap For This Size Bolt or Screw
Drill Size	Dec. Equiv.			Drill Size	Dec. Equiv.			Drill Size	Dec. Equiv.	
60	0.0400			9/64	0.1406			E	0.2500	
59	0.0410			27	0.1440	9 x 30		F	0.2570	5/16 x 18
58	0.0420			26	0.1470	3/16 x 24		G	0.2610	
57	0.0430			25	0.1495	10 x 24	No. 14	17/64	0.2656	5/16 x 18"
56	0.0465	0 x 80		24	0.1520			H	0.2660	
3/64	0.0469			23	0.1540	10 x 28		I	0.2720	5/16 x 24
55	0.0520			5/32	0.1562			J	0.2770	
54	0.0550	1 x 56	No. 3	22	0.1570	10 x 30		K	0.2810	
53	0.0595	1 x 64-72		21	0.1590	10 x 32		9/32	0.2812	5/16 x 24-32"
1/16	0.0625			20	0.1610	3/16 x 32		L	0.2900	
52	0.0635		No. 4	19	0.1660			M	0.2950	
51	0.0670			18	0.1695		No. 16	19/64	0.2969	
50	0.0700	2 x 56-64		11/64	0.1719			N	0.3020	
49	0.0730		No. 5	17	0.1730			5/16	0.3125	3/8 x 16-1/8" P
48	0.0760			16	0.1770	12 x 24		O	0.3160	
5/64	0.0781			15	0.1800			P	0.3230	
47	0.0785	3 x 48	No. 6	14	0.1820	12 x 28		21/64	0.3281	3/8 x 20-24
46	0.0810			13	0.1850	12 x 32	No. 18	Q	0.3332	
45	0.0820	3 x 56		3/16	0.1875			R	0.3390	
44	0.0860	4 x 36	No. 7	12	0.1890			11/32	0.3437	
43	0.0890	4 x 40		11	0.1910			S	0.3480	
42	0.0935	4 x 48		10	0.1935	14 x 20		T	0.3580	
3/32	0.0937			9	0.1960			23/64	0.3594	
41	0.0960			8	0.1990			U	0.3680	
40	0.0980	5 x 36	No. 8	7	0.2010	1/4 x 20		3/8	0.3750	7/16 x 14
39	0.0995			13/64	0.2031			V	0.3770	
38	0.1015	5 x 40		6	0.2040			W	0.3860	
37	0.1040	5 x 44	No. 9	5	0.2055			25/64	0.3906	7/16 x 20
36	0.1069			4	0.2090	1/4 x 24	No. 20	X	0.3970	
7/64	0.1094			3	0.2130	1/4 x 28		Y	0.4040	
35	0.1100	6 x 32		7/32	0.2187	1/4 x 32		13/32	0.4062	
34	0.1110	6 x 36		2	0.2210			Z	0.4130	
33	0.1130	6 x 40	No. 10	1	0.2280		No. 24	27/64	0.4219	1/2 x 12-13
32	0.1160			A	0.2340			7/16	0.4375	1/4" Pipe
31	0.1200		No. 11	15/64	0.2344			29/64	0.4531	1/2 x 2, 0.24
1/8	0.1250	7 x 36		B	0.2380			15/32	0.4687	1/2 x 27
30	0.1285	8 x 30	No. 12	C	0.2420			31/64	0.4844	9/16 x 12
29	0.1360	8 x 32-36		D	0.2460			1/2	0.5000	
28	0.1405	8 x 40		1/4	0.2500					

\* All Tap Drill Sizes are for 75% full Thread Except these Sizes Which are 60% full Thread.

**SELF-TAPPING SCREWS**

Screw Size	Metal Thickness		Type A - AB Sharp Pt Use Drill	Screw Size	Metal Thickness		Type A - AB Sharp Pt Use Drill	Screw Size	Metal Thickness		Type B Blunt Pt Use Drill	Screw Size	Metal Thickness		Type B Blunt Pt Use Drill
	Gauge	Inches			Gauge	Inches			Gauge	Inches			Gauge	Inches	
	28	.016	No. 44		26	.019	No. 33		28	.016	No. 44		26	.019	No. 32
	26	.019	44		24	.025	33		26	.019	44		24	.025	32
No. 4	24	.025	42	No. 8	22	.031	32	No. 4	24	.025	43	No. 8	22	.031	32
(.112")	22	.031	42	(.165")	20	.038	31	(.112")	22	.031	42	(.163")	20	.038	32
	20	.038	40		18	.050	30		20	.038	42		18	.050	30
	28	.016	No. 39		26	.019	No. 30		28	.016	No. 37		26	.019	No. 27
	26	.019	39		24	.025	30		26	.019	37		24	.025	27
No. 6	24	.025	39	No. 10	22	.031	30	No. 6	24	.025	36	No. 10	22	.031	27
(.138")	22	.031	38	(.191")	20	.038	29	(.137")	22	.031	36	(.186")	20	.038	27
	20	.038	36		18	.050	25		20	.038	35		18	.050	27
	28	.016	No. 37		24	.025	No. 26		26	.019	No. 32		24	.025	No. 19
	26	.019	37	No. 12	22	.031	25		24	.025	32	No. 12	22	.031	19
No. 7	24	.025	35	(.218")	20	.038	24	No. 7	22	.031	32	(.212")	20	.038	19
(.155")	22	.031	33		18	.050	22	(.151")	20	.038	32		18	.050	18
	20	.038	32		24	.025	No. 15		18	.050	31		22	.031	No. 13
	18	.050	31	No.14	22	.031	12		16	.063	30	1/4"	20	.038	13
				(.251")	20	.038	11					(.243	18	.050	11
					18	.050	9						16	.063	8



# TECHNICAL INFORMATION

A-49

## TAP DRILL SIZES

TAP		TAP DRILL	DECIMAL EQUIV.	THEOR. % OF THREAD	TAP		TAP DRILL	DECIMAL EQUIV.	THEOR. % OF THREAD	TAP		TAP DRILL	DECIMAL EQUIV.	THEOR. % OF THREAD
NOM. SIZE	T.P.I.				NOM. SIZE	T.P.I.				NOM. SIZE	T.P.I.			
0	80	56	0.0465	83	1/4	28	7/32	0.2188	67	7/8	12	51/64	0.7969	72
-	-	3/64	0.0469	81			2	0.2210	63	7/8	14	51/64	0.7969	84
1	64	54	0.0550	89	1/4	32	7/32	0.2188	77			13/16	0.8125	67
		53	0.0595	67	5/16	18	F	0.2570	77	7/8	16	13/16	0.8125	77
1	72	53	0.0595	75			G	0.2610	71	7/8	20	53/64	0.8281	72
		1/16	0.0625	58			17/64	0.2656	65	15/16	12	55/64	0.8594	72
2	58	51	0.0670	82	5/16	20	17/64	0.2656	72	15/16	16	7/8	0.8750	77
		50	0.0700	69	5/16	24	I	0.2720	75	15/16	20	57/64	0.8906	72
		49	0.0730	56			J	0.2770	66	1	8	7/8	0.8750	77
2	64	50	0.0700	79	5/16	32	9/32	0.2812	77			57/64	0.8906	67
		49	0.0730	64	3/8	16	5/16	0.3125	77	1	12	59/64	0.9219	72
3	48	5/64	0.0781	77			O	0.3160	73			15/16	0.9375	58
		47	0.0785	76			P	0.3230	64	1	14	59/64	0.9219	84
		46	0.0810	67	3/8	20	21/64	0.3281	72			15/16	0.9375	67
3	56	46	0.0810	78	3/8	24	Q	0.3320	79	1	16	15/16	0.9375	77
		45	0.0820	73			R	0.3390	67	1	20	61/64	0.9531	72
		44	0.0860	56	3/8	32	11/32	0.3438	77	1-1/8	7	83/64	0.9844	76
4	40	43	0.0890	71	7/16	14	U	0.3680	75			1	1.0000	67
		42	0.0935	57			3/8	0.3750	67	1-1/8	12	1-1/32	0.0312	87
4	48	42	0.0935	68			V	0.3770	65			1-3/64	1.0469	72
		3/32	0.0938	68	7/16	20	W	0.3860	79	1-1/8	16	1-1/16	1.0625	77
5	40	39	0.0995	79			25/64	0.3906	72	1-1/8	18	1-1/16	1.0625	87
		38	0.1015	72	7/16	24	X	0.3970	75	1-1/4	7	1-3/32	1.0938	84
5	44	38	0.1015	79	7/16	28	Y	0.4040	72			1-7/64	1.1094	76
		37	0.1040	71	1/2	13	27/64	0.4219	78			1-1/8	1.1250	67
6	32	36	0.1065	78			7/16	0.4375	63	1-1/4	12	1-5/32	1.1562	87
		7/64	0.1094	70	1/2	20	29/64	0.4531	72			1-11/64	1.1719	72
		35	0.1100	69	1/2	24	29/64	0.4531	87	1-1/4	16	1-3/16	1.1875	77
6	40	33	0.1130	77	1/2	28	15/32	0.4688	67	1-1/4	18	1-3/16	1.1875	87
		32	0.1160	68	9/16	12	15/32	0.4688	87	1-3/8	6	1-3/16	1.1875	87
8	32	29	0.1360	69			31/64	0.4844	72			1-13/64	1.2031	79
		28	0.1405	58	9/16	18	1/2	0.5000	87			1-7/32	1.2188	72
8	36	29	0.1360	78			33/64	0.5156	65			1-15/64	1.2344	65
		28	0.1405	68	9/16	24	33/64	0.5156	87	1-3/8	12	1-9/32	1.2812	87
		9/64	0.1406	68	5/8	11	17/32	0.5312	79			1-19/64	1.2969	72
10	24	25	0.1495	75			35/64	0.5469	66	1-3/8	16	1-5/16	1.3125	77
		24	0.1520	70	5/8	12	35/64	0.5469	72	1-3/8	18	1-5/16	1.3125	87
		23	0.1540	67	5/8	18	9/16	0.5625	87	1-1/2	6	1-5/16	1.3125	87
10	32	22	0.1570	81			37/64	0.5781	65			1-21/64	1.3281	79
		21	0.1590	76	5/8	24	37/64	0.5781	87			1-11/32	1.3438	72
		20	0.1610	71	11/16	12	39/64	0.6094	72			1-23/64	1.3594	65
12	24	17	0.1730	79	11/16	24	41/64	0.6406	87	1-1/2	12	1-13/32	1.4062	87
		16	0.1770	72	3/4	10	41/64	0.6406	84			1-27/64	1.4219	72
		15	0.1800	67			21/32	0.6562	72	1-1/2	16	1-7/16	1.4375	77
12	28	15	0.1800	78	3/4	12	43/64	0.6719	72	1-1/2	18	1-7/16	1.4375	87
		14	0.1820	73	3/4	16	11/16	0.6875	77	1-3/4	16	1-11/16	1.6875	77
		13	0.1850	67	3/4	20	45/64	0.7031	72	2	16	1-15/16	1.9375	77
1/4	20	7	0.2010	75	13/16	12	47/64	0.7344	72	2-1/4	16	2-3/16	2.1875	77
		13/64	0.2031	72	13/16	16	3/4	0.7500	77	2-1/2	16	2-7/16	2.4375	77
		6	0.2040	71	13/16	20	49/64	0.7656	72	2-3/4	16	2-11/16	2.6875	77
		5	0.2055	69	7/8	9	49/64	0.7656	76	3	16	2-15/16	2.9375	77
1/4	24	4	0.2090	76			25/32	0.7812	65					



**METRIC TAP DRILL SIZES**

TAP	TAP DRILL	DECI. EQUIV.	THEOR. % OF THREAD	TAP	TAP DRILL	DECI. EQUIV.	THEOR. % OF THREAD	TAP	TAP DRILL	DECI. EQUIV.	THEOR. % OF THREAD
M1.6 x 0.35	1.25mm	0.0492	77		I	0.2720	67	M22 x 1.5	20.5mm	0.8071	77
	1.3mm	0.0512	66	M8 x 1	7mm	0.2756	77		13/16	0.8125	70
	#55	0.0520	61		J	0.2770	74	M24 x 3	21mm	0.8268	77
M1.8 x 0.35	1.45mm	0.0571	77	M10 x 1.5	8.5mm	0.3346	77		27/32	0.8438	66
	1.5mm	0.0591	66		R	0.3390	71	M24 x 2	22mm	0.8661	77
	#53	0.0595	64	M10 x 1.25	8.75mm	0.3445	77		7/8	0.8750	68
M2 x 0.4	1.6mm	0.0630	77		S	0.3480	71	M27 x 3	24mm	0.9449	77
	#52	0.0635	74	M12 x 1.75	13/32	0.4062	74		61/64	0.9531	72
M2.2 x 0.45	1.75mm	0.0689	77		Z	0.4130	66	M27 x 2	25mm	0.9843	77
	#50	0.0700	72	M12 x 1.25	27/64	0.4219	79		63/64	0.9844	77
M2.5 x 0.45	2.05mm	0.0807	77			0.4331	62	M30 x 3.5	26.5mm	1.0433	77
	#45	0.0820	71	M14 x 2	12mm	0.4724	77		1-1/16	1.0625	66
M3 x 0.5	2.5mm	0.0984	77			0.4844	65	M30 x 2	28mm	1.1024	77
	#39	0.0995	73	M14 x 1.5	12.5mm	0.4921	77		1-7/64	1.1094	70
M3.5 x 0.6	2.9mm	0.1142	77		1/2	0.5000	67	M33 x 3.5	29.5mm	1.1614	77
	#32	0.1160	71	M16 x 2	14mm	0.5512	77		1-11/64	1.1719	71
M4 x 0.7	3.3mm	0.1299	77		9/16	0.5625	66	M33 x 2	31mm	1.2205	77
	3.4mm	0.1339	66	M16 x 1.5	14.5mm	0.5709	77		1-15/64	1.2344	63
	#29	0.1360	60		37/64	0.5781	68	M36 x 4	32mm	1.2598	77
M4.5 x 0.75	3.75mm	0.1476	77	M18 x 2.5	15.5mm	0.6102	77		1-17/64	1.2656	74
	#25	0.1495	72		5/8	0.6250	65	M36 x 3	1-19/64	1.2969	78
M5 x 0.8	4.2mm	0.1654	77	M18 x 1.5	16.5mm	0.6496	77		33mm	1.2992	77
	#18	0.1695	67		21/32	0.6562	68		1-5/16	1.3125	68
M6 x 1	5mm	0.1969	77	M20 x 2.5	17.5mm	0.6890	77	M39 x 4	1-3/8	1.3750	78
	#8	0.1990	73		45/64	0.7031	66		35mm	1.3780	77
M7 x 1	6mm	0.2362	77	M20 x 1.5	18.5mm	0.7283	77		1-25/64	1.3906	71
	B	0.2380	74		47/64	0.7344	69	M39 x 3	36mm	1.4173	77
M8 x 1.25	6.75mm	0.2657	77	M22 x 2.5	19.5mm	0.7677	77		1-27/64	1.4219	74
	6.8mm	0.2677	74		25/32	0.7812	66				

**PIPE TAP DRILL SIZES**

TAP SIZE	*NPT		* NPTF		* STRAIGHT	
	TAP DRILL	DECIM. EQUIV.	TAP DRILL	DECIM. EQUIV.	TAP DRILL	DECIM. EQUIV.
1/16	D	0.2460	D	0.2460	1/4	0.2500
1/8	Q	0.3320	R	0.3390	11/32	0.3438
1/4	7/16	0.4375	7/16	0.4375	7/16	0.4375
3/8	9/16	0.5625	37/64	0.5781	37/64	0.5781
1/2	45/64	0.7031	45/64	0.7031	23/32	0.7188
3/4	29/32	0.9062	59/64	0.9219	59/64	0.9219
1	1-9/64	1.1406	1-5/32	1.1562	1-5/32	1.1562
1-1/4	1-31/64	1.4844	1-1/2	1.5000	1-1/2	1.5000
1-1/2	1-47/64	1.7344	1-47/64	1.7344	1-3/4	1.7500
2	2-13/64	2.2031	2-7/32	2.2188	2-7/32	2.2188
2-1/2	2-5/8	2.6250	2-41/64	2.6406	2-21/32	2.6562
3			3-17/64	3.2656		

\* FOR TAPPING WITHOUT REAMING





Office No.02, 1st Floor, Shreeji Plaza, CHS Tata Road  
No 02 , Opera House, Charni Road Mumbai - 400004



[info@adcoforge.com](mailto:info@adcoforge.com)

GST NO : 27AAXCA2226N1Z4



+91-22-6659 5582 / 6659 5581 /  
4602 5379 (15 Lines)



[www.adcoforge.com](http://www.adcoforge.com)