

ANSI/ ASME B16.36 Orifice Flanges Catalogue

- ☒ **Wide range of materials, including**
 - ASTM A105N Carbon Steel
 - ASTM A350 LF2 Carbon Steel
 - ASTM A182 F316L Stainless Steel
- ☒ **Ratings from 300 lb to 2500 lb**
- ☒ **Sizes from 1" Nominal Bore**
- ☒ **Corner Tapping Versions Available**

General Description

Orifice flanges are intended for use instead of standard pipe flanges when an orifice plate or flow nozzle must be installed. Pairs of pres-sure tapplings are machined into the orifice flange, making separate orifice carriers or tapplings in the pipe wall unnecessary.

The range of orifice flanges covers all standard sizes and ranges, and all common flange materials. Flanges are available in socket weld or weld neck form, and are typically supplied with two ½" NPT tapplings in each flange. Jacking screws to ensure ease of removal of the pri-mary flow element are provided.

Orifice plates and flow nozzles can also be supplied. See individual Product Data Sheets for more information.

Orifice flanges may also be supplied complete with bolting and gasket kits.

Materials

We can supply orifice flanges in a wide range of standard and special materials, including:

ASTM A105 Carbon Steel
 ASTM A350 LF2 Low Temp Carbon Steel
 ASTM A182 F316 Stainless Steel
 ASTM A182 F304 Stainless Steel
 ASTM A182 F11 1¼% Cr ½% Mo
 ASTM A182 F22 2¼% Cr 1% Mo

Pressure Tapplings

As standard, two ½" NPT tapplings are provided in each flange, one with a plug. Other thread sizes are available on request. Socket weld connections may be specified, and butt weld pipe nipples are also available. Tapplings are generally 'flange' type, but corner tapplings are optional.

Gaskets

A range of suitable gaskets for use with orifice flanges is also available.

Typical specifications include:

- 1.5 mm thick IBC ring type, non asbesto
- 3.2 mm thick sprial wound type,
- carbon steel outer, stainless
- steel inner, 316L
- windings with graphite filler



Studbolts and Nuts

Suitable bolting may be supplied on request. Standard materials include:

- ASTM A193 B7 and ASTM A194 Gr 2H
- ASTM A320 L7 and ASTM A194 Gr 4 or 7
- ASTM A320 B8 and ASTM A194 Gr 8 Bolting

conforming to NACE is also available.



Office No.02, 1st Floor, Shreeji Plaza, CHS Tata Road
 No 02 , Opera House, Charni Road Mumbai - 400004



info@adcoforge.com

GST NO : 27AAXCA2226N1Z4



+91-22-6659 5582 / 6659 5581 /
 4602 5379 (15 Lines)



www.adcoforge.com

Weldneck Orifice Flange Assemblies

Weldneck orifice flanges are butt-welded into the pipeline. The inside diameter (or the schedule) of the pipe should be specified when ordering.

Bolt sizes, weights and important dimensions of orifice flange assemblies are shown in the following tables.

Weldneck orifice flanges are available in classes 300, 600, 900, 1500 and 2500. Raised face (RF) and ring type joint (RTJ) versions can be supplied.

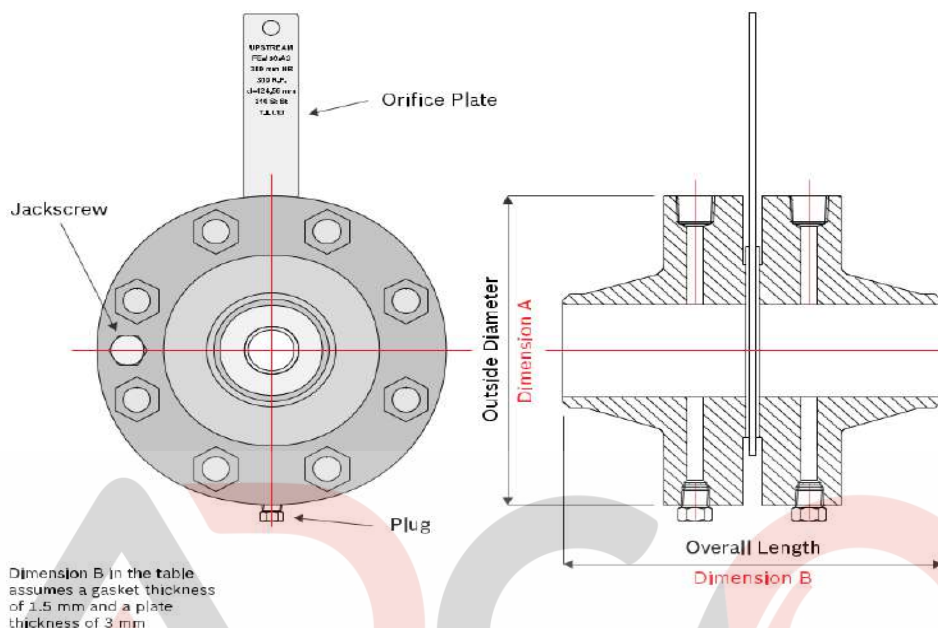

Nominal Size		Weldneck Orifice Flanges - 300 lb RF				
		Bolts		Approx. weight (kg)	Dimensions	
mm	Inches	Bolt Qty	Bolt Sizes		B	A
25	1	4	5/8" x 5.00"	9	171	124
40	1 1/2	4	3/4" x 5.25"	13	178	155
50	2	8	5/8" x 5.00"	14	178	165
65	2 1/2	8	3/4" x 5.25"	18	184	191
80	3	8	3/4" x 5.25"	21	184	210
100	4	8	3/4" 5.25"	31	190	254
150	6	12	3/4" x 5.25"	50	206	318
200	8	12	7/8" x 5.75"	73	229	381
250	10	16	1" x 6.50"	100	241	445
300	12	16	1 1/8" x 7.00"	151	266	521
350	14	20	1 1/8" x 7.25"	207	291	584
400	16	20	1 1/4" x 7.75"	275	298	648
450	18	24	1 1/4" x 8.00"	341	324	711
500	20	24	1 1/4" x 8.50"	408	330	775
600	24	24	1 1/2" x 9.50"	604	342	914

all dimensions are in mm



Office No.02, 1st Floor, Shreeji Plaza, CHS Tata Road
 No 02 , Opera House, Charni Road Mumbai - 400004



info@adcoforge.com

GST NO : 27AAXCA2226N1Z4



+91-22-6659 5582 / 6659 5581 /
 4602 5379 (15 Lines)



www.adcoforge.com

Nominal Size		Weldneck Orifice Flanges - 600 lb RF				
		Bolts		Approx. weight (kg)	Dimensions	
mm	Inches	Bolt Qty	Bolt Sizes		B	A
25	1	4	5/8" x 5.00"	9	171	124
40	1 1/2	4	3/4" x 5.25"	13	178	155
50	2	8	5/8" x 5.00"	14	178	165
65	2 1/2	8	3/4" x 5.25"	18	184	191
80	3	8	3/4" x 5.25"	21	184	210
100	4	8	7/8" 6.00"	41	209	273
150	6	12	1" x 7.00"	82	241	356
200	8	12	1 1/8" x 7.75"	124	273	419
250	10	16	1 1/4" x 8.75"	208	311	508
300	12	20	1 1/4" x 9.00"	250	317	559
350	14	20	1 3/8" x 9.50"	-	336	603
400	16	20	1 1/2" x 10.25"	-	362	686
450	18	20	1 5/8" x 11.00"	-	374	743
500	20	24	1 5/8" x 11.75"	-	387	813
600	24	24	1 7/8" x 13.25"	-	412	940

Nominal Size		Weldneck Orifice Flanges - 900 lb RF				
		Bolts		Approx. weight (kg)	Dimensions	
mm	Inches	Bolt Qty	Bolt Sizes		B	A
25	1	4	7/8 x 6.00"	13	171	149
40	1 1/2	4	1" x 6.25"	18	184	178
50	2	8	7/8" x 6.00"	29	209	216
65	2 1/2	8	1" x 6.50"	41	215	244
80	3	8	7/8" x 6.00"	34	209	241
100	4	8	1 1/8" x 7.00"	59	235	292
150	6	12	1 1/8" x 7.75"	120	285	381
200	8	12	1 3/8" x 9.00"	204	330	470
250	10	16	1 3/8" x 9.50"	291	374	546
300	12	20	1 3/8" x 10.25"	405	406	610
350	14	20	1 1/2" x 11.00"	-	431	641
400	16	20	1 5/8" x 11.50"	-	438	705
450	18	20	1 7/8 x 13.00"	-	463	787
500	20	20	2" x 14.00"	-	501	857
600	24	20	2 1/2" x 17.50"	-	590	1041

Nominal Size		Weldneck Orifice Flanges - 1500 lb RF				
		Bolts		Approx. weight (kg)	Dimensions	
mm	Inches	Bolt Qty	Bolt Sizes		B	A
25	1	4	7/8 x 6.00"	13	171	149
40	1 1/2	4	1" x 6.25"	18	184	178
50	2	8	7/8" x 6.00"	29	209	216
65	2 1/2	8	1" x 6.50"	41	215	244
80	3	8	1 1/8" x 7.25"	58	241	267
100	4	8	1 1/4" x 8.00"	82	254	311
150	6	12	1 3/8" x 10.50"	186	349	394
200	8	12	1 5/8" x 11.75"	306	432	483
250	10	12	1 7/8" x 13.50"	500	514	584
300	12	16	2" x 15.00"	764	571	673
350	14	16	2 1/4" x 16.25"	-	603	749
400	16	16	2 1/2" x 17.75"	-	628	826
450	18	16	2 3/4" x 19.75"	-	660	914
500	20	16	3" x 21.50"	-	717	984
600	24	16	3 1/2" x 24.50"	-	819	1168



Slip-On Orifice Flange Assemblies

Slip-on orifice flanges are designed to slip over the pipeline before welding.

Slip-on orifice flanges are available in class 300, with a raised face (RF).

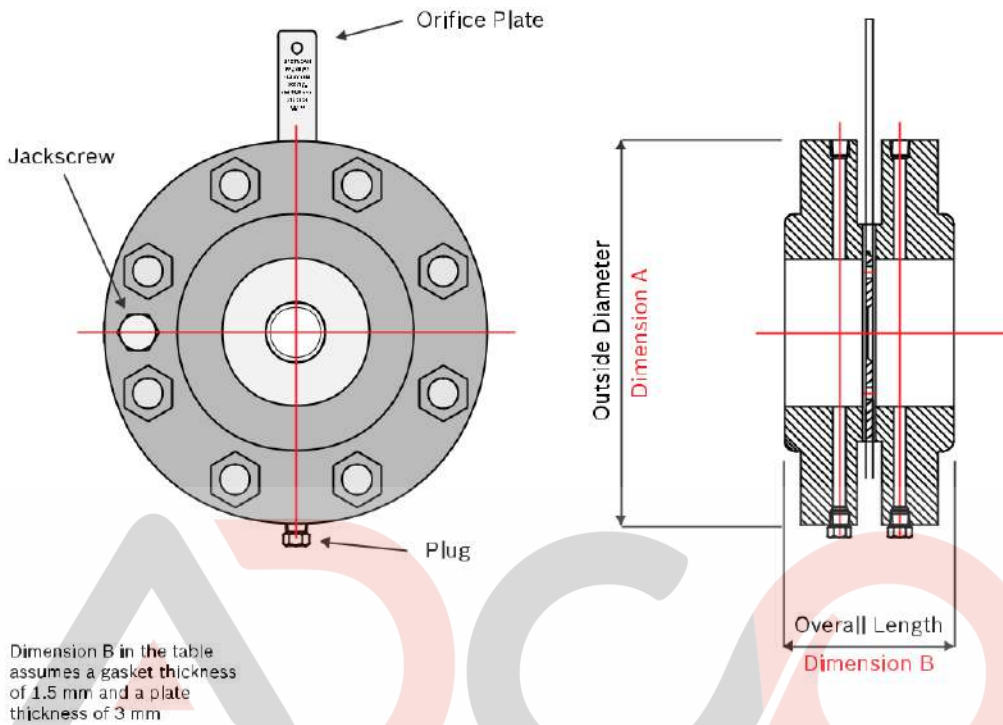

Nominal Size		Slip-On Orifice Flanges - 300 lb RF				
mm	Inches	Bolts		Approx. weight (kg)	Dimensions	
		Bolt Qty	Bolt Sizes		B	A
25	1	4	5/8" x 5.00"	7.5	102	124
40	1 1/2	4	3/4" x 5.25"	9.3	102	155
50	2	8	5/8" x 5.00"	11.5	105	165
65	2 1/2	8	3/4" x 5.25"	15	108	191
80	3	8	3/4" x 5.25"	19	111	210
100	4	8	3/4" x 5.25"	29	114	254
150	6	12	3/4" x 5.25"	50	114	318
200	8	12	7/8" x 5.75"	65	130	381
250	10	16	1" x 6.50"	91	139	445
300	12	16	1 1/8" x 7.00"	133	152	521
350	14	20	1 1/8" x 7.25"	177	158	584
400	16	20	1 1/4" x 7.75"	240	171	648
450	18	24	1 1/4" x 8.00"	323	184	711
500	20	24	1 1/4" x 8.50"	360	197	775
600	24	24	1 1/2" x 9.50"	555	219	914

all dimensions are in mm



Office No.02, 1st Floor, Shreeji Plaza, CHS Tata Road
 No 02, Opera House, Charni Road Mumbai - 400004



info@adcoforge.com

GST NO : 27AAXCA2226N1Z4



+91-22-6659 5582 / 6659 5581 /
 4602 5379 (15 Lines)



www.adcoforge.com